

# MANISCOPIC

# ■ MRT 1640 EASY



- Lift height: 15,80 m
- Max. reach: 13,50 m
- Engine: 101 HP - 74,5 kW
- 4 wheel drive - 4 wheel steer
- Hydrostatic transmission

 **MANITOU**

**ROTATION ON STABILISERS WITH FORKS**

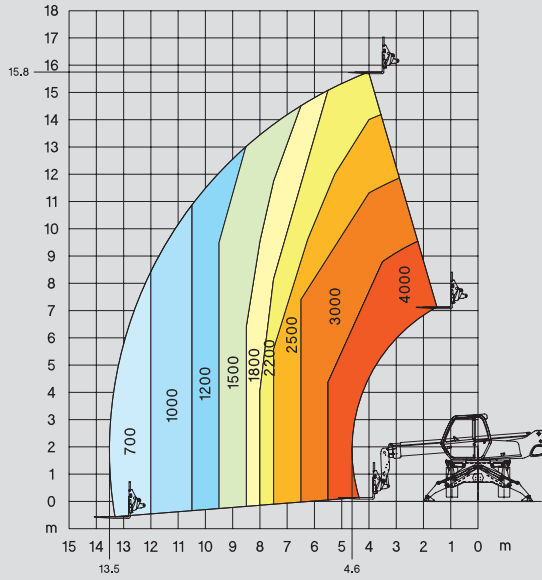

**FRONTAL POSITION ON WHEELS WITH FORKS**

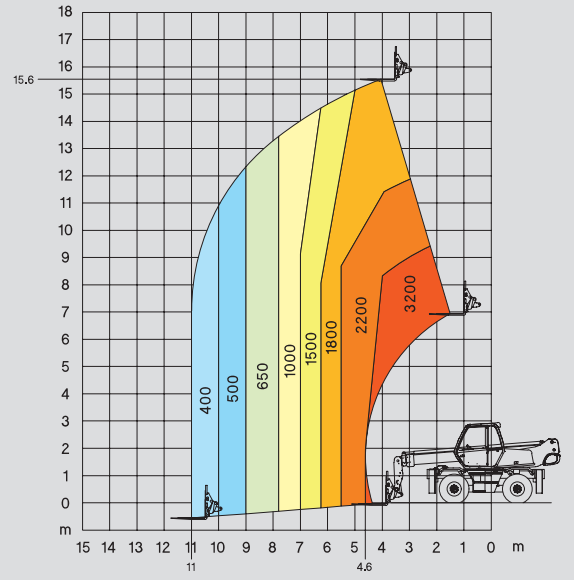

**ROTATION ON WHEELS WITH FORKS**

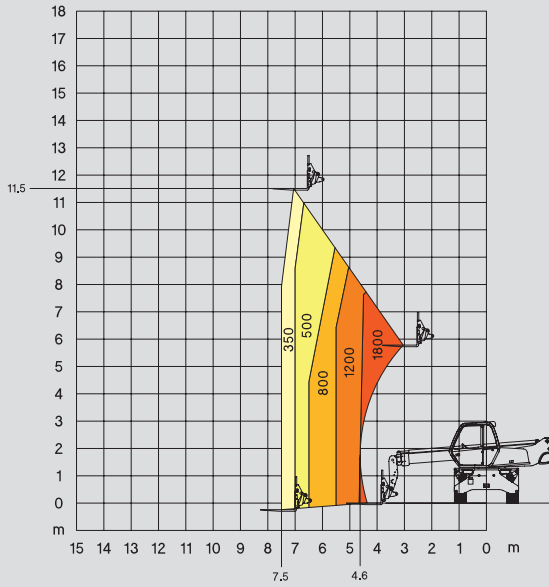

**ROTATION ON STABILISERS WITH 4 T WINCH**

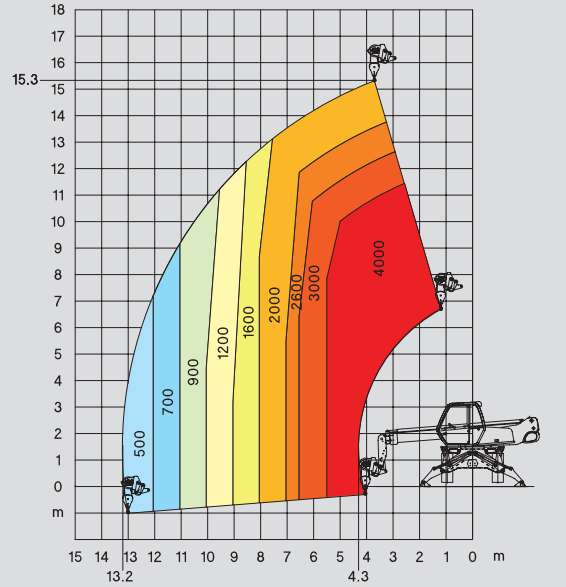

**ROTATION ON STABILISERS WITH JIB P 600**

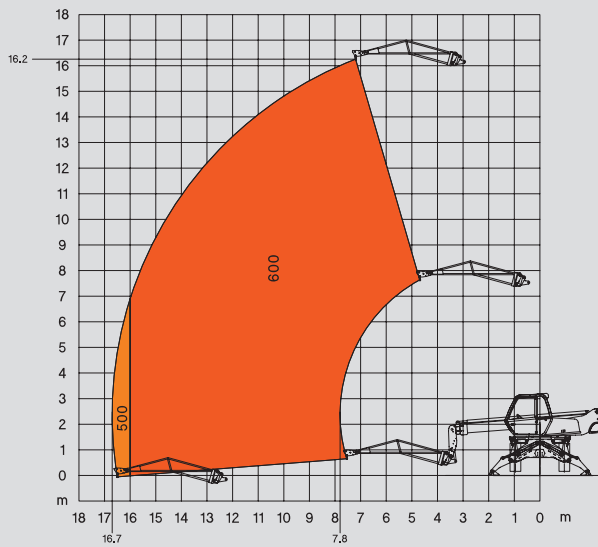

**ROTATION ON STABILISERS WITH JIB P 1500**

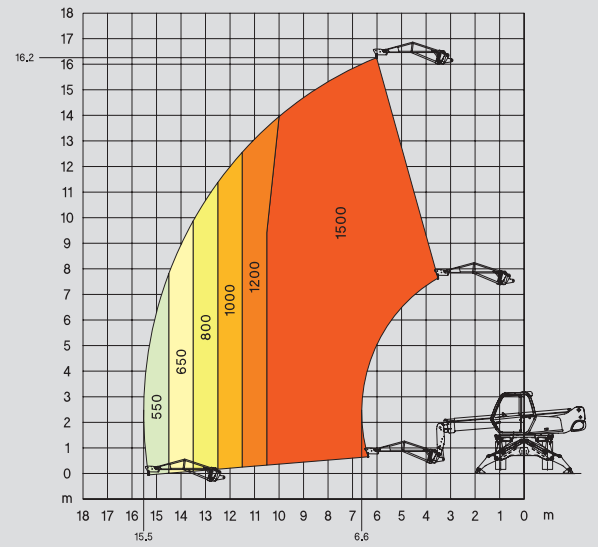

**ROTATION ON STABILISERS  
WITH 365 KG PLATFORM ORH - 2,25/4 m**

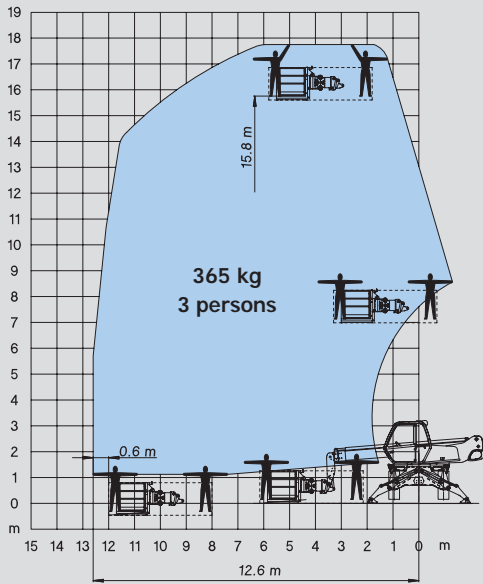

**ROTATION ON STABILISERS  
WITH 1000 KG PLATFORM ORH - 2,25/4 m**

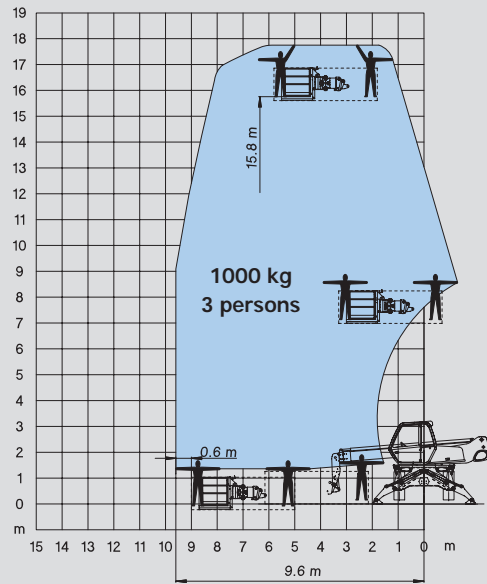

**ROTATION ON STABILISERS FULLY EXTENDED  
WITH AERIAL JIB 2 PLATFORM IN POSITIVE POSITION**

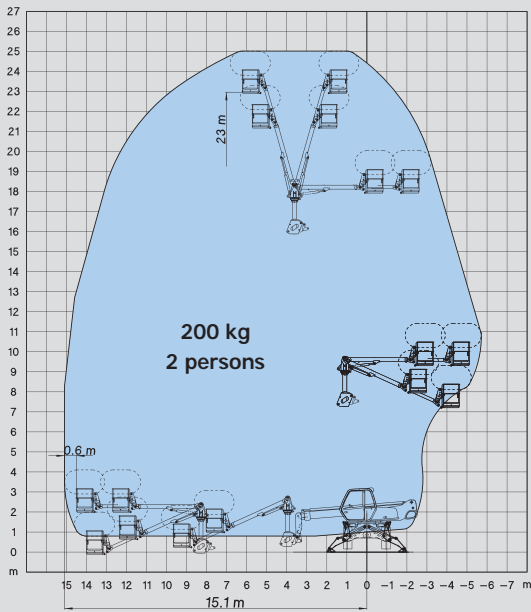

**ROTATION ON STABILISERS FULLY EXTENDED  
WITH AERIAL JIB 2 PLATFORM IN NEGATIVE POSITION**

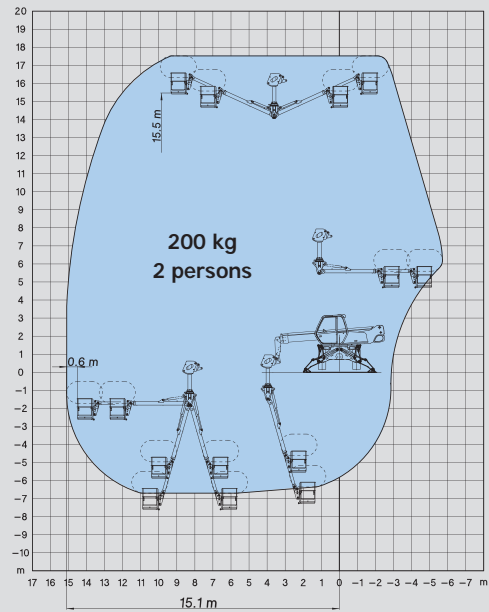

**ROTATION ON STABILISERS FULLY EXTENDED  
WITH AERIAL JIB 1**

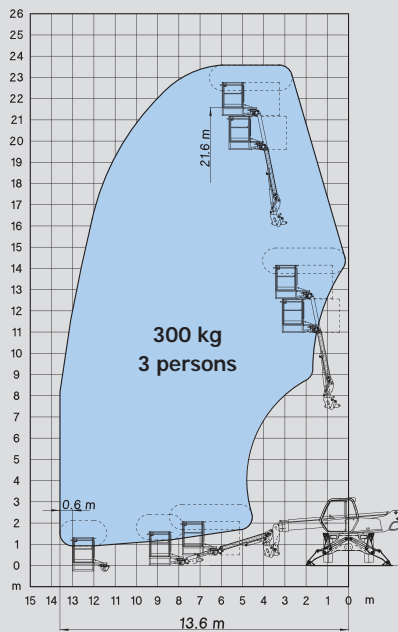

## MRT 1640 *EASY*

 **Lift capacity** ..... 4000 kg  
(on stabilisers) at 500 mm from forks heels

 **Lift height** ..... 15,80 m

 **Tyres** ..... 400/70 - 20 14 PR

 **Forks (mm)**  
Length ..... 1200  
Width x thickness ..... 150 x 50

 **Multidisc brakes**  
Hydraulically assisted on front axle  
Negative parking brake

 **Engine PERKINS**  
Type ..... 1104D-E44 T  
Capacity ..... 4 cyl. - 4400 cm<sup>3</sup>  
Power (ISO/TR 14396) ..... 101 HP/74,5 kW  
at 2200 rpm  
Maximum torque ..... 392 Nm at 1400 rpm  
Water cooling  
Direct injection

 **Transmission** hydrostatic with automatic power regulation (variable displacement pump and motor) with control inching  
Reversing shift ..... electromagnetic  
Speed forward and reverse ..... 2/2  
Travel speed ..... 35 km/h

 **Rear axle**  
Automatic rear axle locking system at a rotation over 5°

 **4 stabilisers**  
simultaneous or individually controlled

 **Rotation through 400°** (Optional 360° continuous rotation)  
Turret mounted on a double slew ring  
Slewing system with negative brake

 **Hydraulics**  
2 pumps gear type ..... 270 bars/115 l/mn

 **Control** : 2 electro proportional control joysticks for all hydraulic movements

 **Capacities**  
Cooling system ..... 25 l.  
Engine oil ..... 8,1 l.  
Hydraulic oil ..... 150 l.  
Fuel tank ..... 130 l.

 **Weight unladen (with forks)** ..... 13000 kg  
**Overall width** ..... 2,40 m  
**Overall height** ..... 2,97 m  
**Length (forks carriage)** ..... 6,36 m  
**Ground clearance** ..... 0,34 m  
**Drawbar pull** ..... 8600 daN

 **Safety**  
**Standard load moment indicator**  
(mobile crane standards)

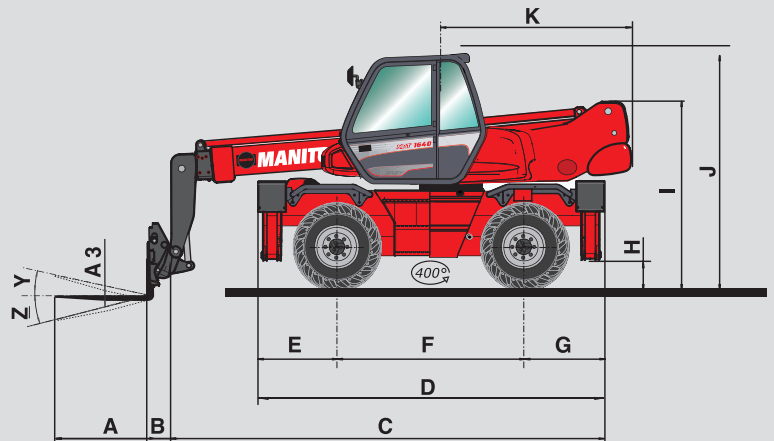

A	1200
A1	150
A2	1320
A3	50
B	290
C	6075
D	4350
E	1015
F	2320
G	1015
H	340
I	2375
J	2970
K	2485
L	1930
M	2400
N	3715
O	3975
P	160
Q	3900
R	3410
S	4000
T	3600
U	5520
V	950
Y	12°
Z	105°

mm

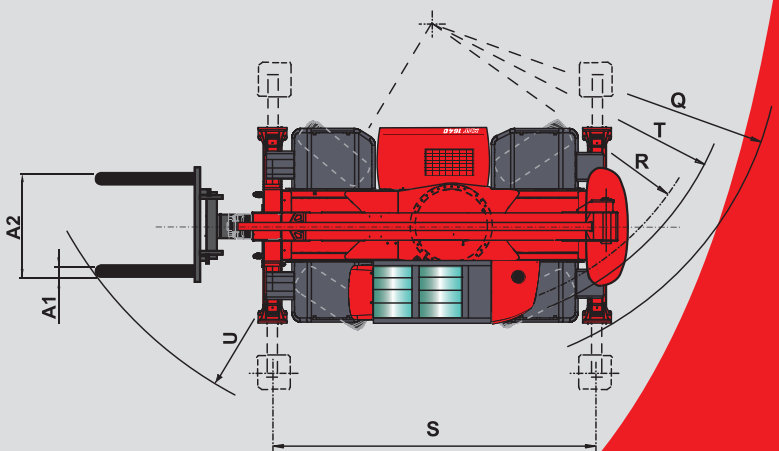
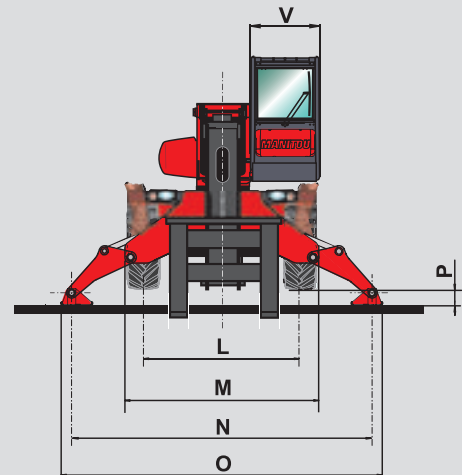

**CE** This publication in no way constitutes an offer and the company reserves the right to alter specification without prior notice. The MANITOU models presented in this brochure can be supplied complete with optional equipment attachments.

MANITOU BF SA  
B.P. 249 - 44158 Ancenis Cedex - France  
Tel : 33 2 40 09 10 11 - Export Department Fax : 33 2 40 09 10 97  
www.manitou.com

700446EN\_A\_0710\_MRT1640EASY.indd

 **MANITOU**