

KOMATSU®

HD1500-7

GROSS HORSEPOWER

1119 kW **1,500 HP**

NOMINAL GVW

249478 kg **550,000 lb**

HD
1500

MECHANICAL DRIVE TRUCK



Photos may include optional equipment

WALK-AROUND

Productivity Features

- High performance Komatsu SDA16V159E-2 engine meets EPA Tier 2 emissions regulations
Gross horsepower 1119 kW **1,500 HP**
- Komatsu electronically controlled, automatic seven-speed powershift transmission
- Advanced K-ATOMiCS clutch modulation system with Skip-shift function
- Automatic Spin Regulator (ASR) for traction control
- Automatic Retard Speed Control (ARSC)
- Tight turning radius 12.2 m **40'**
- MacPherson-type independent suspension
- Integrated Komatsu Payload Meter
- Standard rock body and customer specific design available

Reliability Features

- Enhanced frame design rated for
144 metric ton **159 short ton** payload
- Rugged and durable dump body design
- Steering and brake accumulators
- Proven and reliable hydraulic system
- Hydraulically actuated, multiple-disc
wet brakes



GROSS HORSEPOWER
1119 kW 1,500 HP

NOMINAL GVW
249478 kg 550,000 lb

Operator Environment

- Ergonomically designed, spacious cab with excellent visibility
- Fully adjustable driving position settings
- Four post ROPS/FOPS Level 2
- Advanced dash panel with payload display
- Auxiliary brake and automatic application
- AM/FM/CD/MP3/USB radio



Easy Maintenance

- KOMTRAX Plus allows immediate diagnosis of key engine, chassis, and drive system components
- Oil-cooled wet disc braking system reduces wear and extends component replacement intervals
- Automatic lubrication system
- Remote mounted transmission
- In-tank fast fuel system

PRODUCTIVITY FEATURES

Komatsu SDA16V159E-2 Engine

The Komatsu SDA16V159E-2 engine with 1119 kW **1,500 HP** gross horsepower delivers greater acceleration and higher travel speeds with a high horsepower-to-ton ratio. High torque at low speeds and impressive acceleration ensure maximum productivity with low fuel consumption. Standard features of this engine include:

- Pre-lube system designed to eliminate start-up wear and increase overhaul life
- CENSE® on board monitoring of engine performance for each cylinder



Powershift Transmission

Komatsu's HD1500-7 features a fully electronically controlled, automatic seven-speed powershift transmission. Main transmission features include:

- Electronic shift control with automatic clutch modulation in all gears
- Transmission-mounted torque converter
- Lock-up clutch system that is activated in every forward shift change
- Separate hydraulic circuit and cooler
- Rubber damper that reduces harmful engine shocks and torsional vibration to the transmission

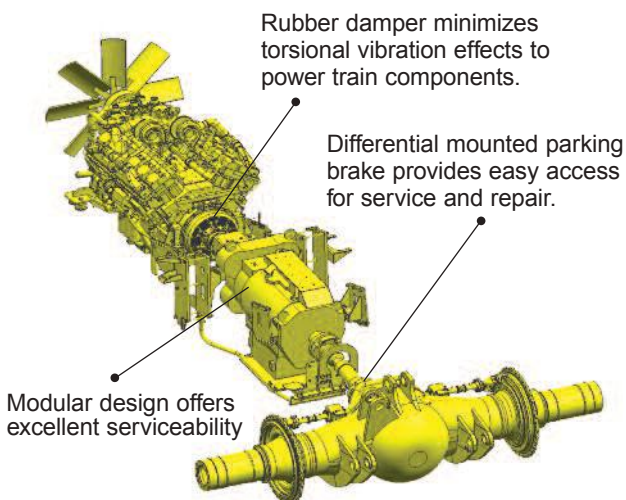

Advanced K-ATOMiCS with Skip-shift

The electronically controlled all clutch modulation system (K-ATOMiCS), optimizes the clutch engagement oil pressure at every gear. This system optimizes the clutch lock-up process for smoother shifting with minimal torque shock.

Skip-shift Function

When driving uphill, the skip-shift function automatically selects the gear according to the slope of the grade. This function reduces the number of down-shifts, making the driving smoother, improving the operator's comfort and reducing potential material spillage.

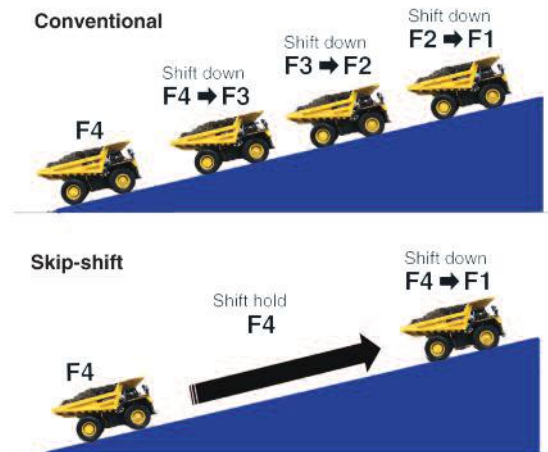

Automatic Spin Regulator (ASR)

During slippery conditions, the traction control provided by the ASR detects and corrects wheel spin on rear tires by applying braking force independently to the drive wheels. The ASR operates independently of the service brake system, providing an additional means of controlling the machine in slippery conditions.

Automatic Retard Speed Control (ARSC)

ARSC allows the operator to set a desired machine speed according to the grade of the road. This function manages the speed of all four wheels, allowing adjustments of the desired speed on grade by using the options available in the ARSC lever.

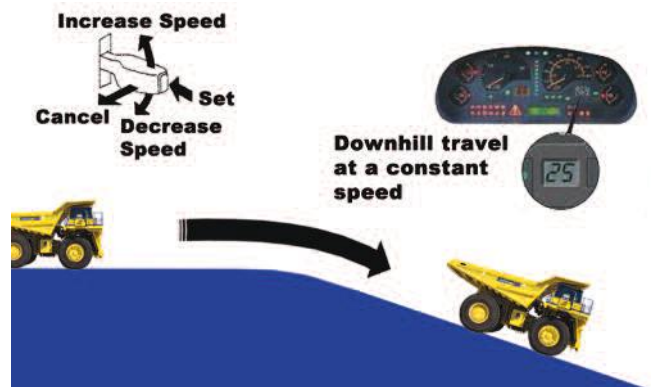

Steering System

The MacPherson front suspension system has a special A-frame between each wheel and the main frame. The wider space created between the front wheels and the main frame increases the turning angle of the wheels. The turning radius of the HD1500-7 is 12.2 m **40'**, which provides excellent maneuverability in tight loading and dumping conditions. In addition, a secondary steering system provides emergency hydraulic power in the case of sudden loss of engine power or steering hydraulic pressure. The steering accumulators comply with ISO-5010 standards.



Integrated Komatsu Payload Meter

Integrated Komatsu Payload Meter is an electronic system that monitors and records payload information for Komatsu's off-highway mining trucks. The accurate and reliable payload measurement system is designed to help optimize payload, maximize productivity and reduce the life cycle cost of the machine. Integrated Komatsu Payload Meter tracks and records the following key production parameters:

- Payload
- Operator Identification
- Haul Cycle, Loading, Dumping Time and Date
- Distance Traveled (Loaded and Empty)
- Maximum Speed

Suspension

The linkage arrangement utilized in the MacPherson independent front suspension system allows the front wheels to smoothly follow the undulation of the road surface, providing excellent riding comfort.

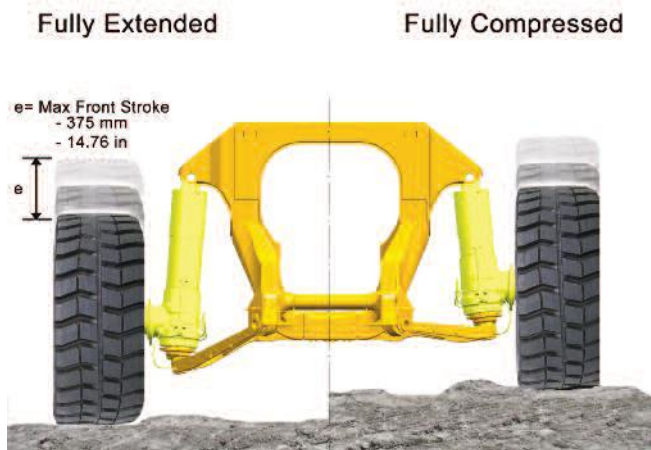

Customer Specific Body

Komatsu works with each customer to understand and meet all of the criteria for body capacity and distribution. The Komatsu Body Worksheet (BW) process obtains the appropriate information from the customer about key factors that will help to determine the correct body for their site.

Komatsu offers a standard all-welded steel, flat floor body with an over the cab canopy and horizontal bolsters.

- Standard Body Struck Capacity: 54 m³ **71 yd³**
- Standard Body SAE Heaped 2:1: 78 m³ **102 yd³**
- Standard Komatsu Body Weight: 19100 kg **42,108 lbs**



OPERATOR ENVIRONMENT

Ergonomically Designed Cab

The Komatsu HD1500-7 cab provides a comfortable and productive environment to meet today's mining market demand. The cab includes tinted glass windows, heating and air conditioning, acoustical insulation, double sealed doors, and pressurized air filtration system. The instrument panel makes it easy to monitor critical machine functions.

Machine events are recorded and indicated as service codes. A caution light warns the operator of any problems that may occur. This makes the machine more user friendly and easier to service.

Operator Seat

Komatsu recognizes that operator comfort is a key to productivity in today's mining environment. The five-way adjustable operator seat and the tilt-telescopic steering column provide an optimum driving posture for increased comfort and control over the machine. The suspension seat absorbs vibrations transmitted from the machine while reducing operator fatigue.

Built-in ROPS and FOPS Structure

Komatsu offers an integral ROPS/FOPS Level 2 cab that conforms to ISO standards 3471 and 3449.

Auxiliary Brake and Automatic Application

All four wet disc brakes are activated when the auxiliary brake button, located on the dashboard, is pressed. In addition, the brakes will be automatically applied when the hydraulic pressure drops below the specified level.

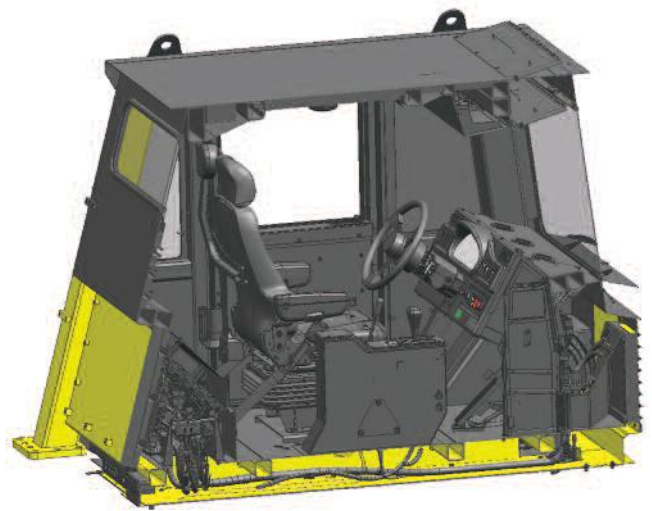

RELIABILITY FEATURES

Enhanced Frame Design

The HD1500-7 frame has been enhanced to meet more stringent Komatsu Engineering Standards (KES). This enhanced frame design focuses on improving stress distribution in order to offer superior strength. Furthermore, increased casting thickness in high stress areas provides the structural flexibility needed to carry loads and absorb impacts in the toughest haul road conditions.

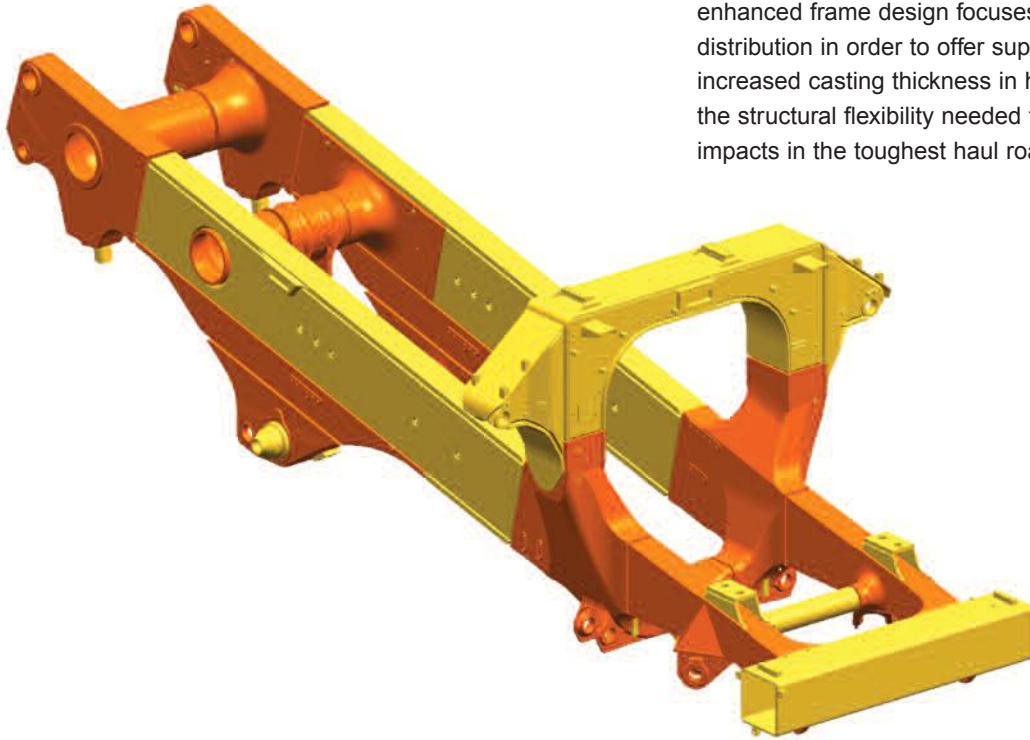

Service Brakes

The HD1500-7 comes standard with four-wheel, hydraulically actuated, oil-cooled service brakes. By using a fully hydraulic braking system, the formation of water and sediments - typical in air actuated braking systems - is no longer present. This helps prevent contamination, freezing and corrosion from affecting service brake component life. The HD1500-7 stopping distance is well within ISO 3450 braking standard.

Rugged and Durable Dump Body Design

The standard dump body is made of high tensile strength steel with a Brinell hardness of 400 for excellent rigidity and reduced maintenance cost. The side and bottom plates of the dump section are reinforced with ribs for additional strength.

Hoist Cylinders

The newly designed three-stage cylinders deliver smooth and reliable dumping by using an internal cushion valve and over-center damping. Internally, the cylinders have a quill assembly that modulates the body return speed after dumping. This reduces forces transferred to the frame, body and suspension cylinders.



Simple and Reliable Hydraulic System

The hydraulic system is a proven and reliable design with fewer parts than other OEMs. The system utilizes a single tank, providing one common source of fluid for steering, braking, and hoisting. In-line, replaceable filtration elements provide protection from hydraulic system contamination. This makes the system easier to service.

EASY MAINTENANCE

Automatic Lubrication System

The automatic lubrication system is designed to reduce service downtime and improve durability of all pin joints by having a centralized module that automatically distributes grease at adjustable intervals. In addition, this hydraulically activated system can be adjusted to deliver the precise amount of grease required by each joint.



Rear LED Lighting Rack

An LED lighting rack at the rear of the truck provides rear, brake and flasher lights. In addition, this bracket, protected from falling objects by the body structure, includes the back-up warning horn and warning lights.

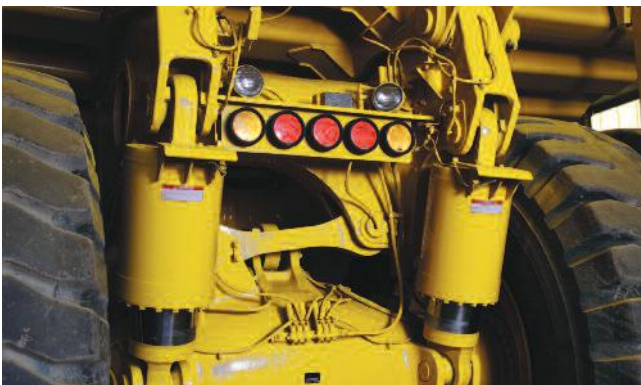

KOMTRAX Plus

As part of a complete service and support program, Komatsu equips every truck with KOMTRAX Plus. By using a satellite-based communication system, KOMTRAX Plus provides access to machine health parameters and trends, payloads, and critical faults in a user friendly web interface.

The information available through KOMTRAX Plus allows service personnel to review faults and trends, improve the quality of the troubleshooting process and reduce unscheduled machine downtime.

KOMTRAX Plus



O-Ring Face Seals & Sealed DT Connectors

O-ring face seals provide superior leak protection. All hydraulic hose male connections have a straight thread and o-ring in the face. The female connections have a straight thread and machined flat face.

Komatsu trucks use Deutsch connectors in main harnesses and controller connectors of its electrical wiring. Compact, hermetically sealed, resistant to temperature and vibration and easy to use, Deutsch connectors are designed to withstand the harshest and most challenging environments.

PAYLOAD MANAGEMENT

Payload Policy

10-10-20 Load Policy Criteria

Recognizing that variation occurs naturally in material density, fill factors, and loading equipment, Komatsu America Corp. deems it necessary to establish a consistent payload policy. This payload policy is intended to identify the guidelines and limitations for the loading of Komatsu mining trucks, and is valid for approved applications and haul profiles only.

- 1) The average monthly payload must not exceed the rated payload of the truck.
- 2) 90% of all loads must be below 110% of the rated payload of the truck.
- 3) 10% of all loads may be between 110% and 120% of the rated payload of the truck.
- 4) No single payload may exceed 120% of the rated payload of the truck.

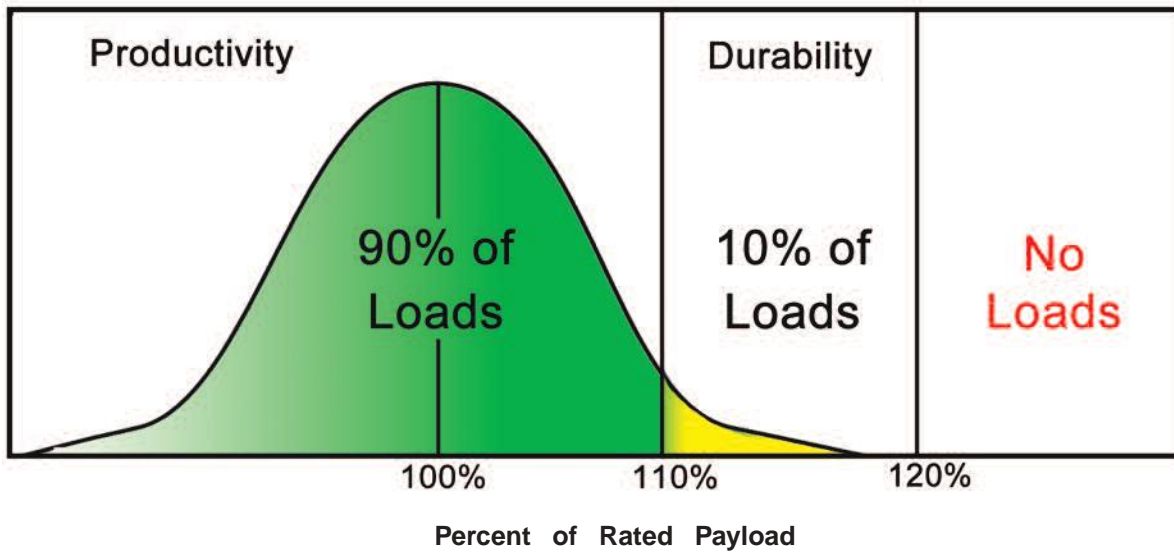

KOMATSU LOADING MATCH CHART

Typical Number of Passes to Load

		Komatsu Trucks							
		HD785 100 ton	HD1500 159 ton	730E 203 ton	830E-AC 244 ton	860E-1K 280 ton	930E-4 320 ton	930E-4SE 320 ton	960E 360 ton
KOMATSU EXCAVATORS	PC2000 15.7 yd ³	4	7						
	PC3000 19.5 yd ³	4	6	7					
	PC4000 29 yd ³	3	4	5	6	6			
	PC5500 37 yd ³		3	4	5	5	6	6	7
	PC8000 55 yd ³				3	3	4	4	5

Nominal truck payload rating (short tons)
 Bucket ratings are based on 1780 kg/lcm **3,000 lbs/lcm** material density.

HD1500-7 MECHANICAL DRIVE TRUCK

SPECIFICATIONS



ENGINE

Model	Komatsu SDA16V159E-2	
Type	Water-cooled, 4-cycle	
Aspiration	Turbo-charged, after-cooled	
Number of cylinders	16	
Bore x Stroke	159 mm x 159 mm 6.26" x 6.26"	
Piston displacement	50 ltr 3,066 in	
Horsepower		
SAE J1995	Gross 1119 kW	1,500 HP
ISO 9249 / SAE J1349	Net 1043 kW	1,399 HP
Rated rpm	1,900 rpm	
Fan drive type	Electronic controlled hydraulic	
Maximum torque	697 kg•m	5,042 lb ft
Fuel system	Direct injection	
Governor	Electronic control	
Lubrication system		
Method	Gear pump, force-lubrication	
Filter	Full-flow type	
Air cleaner	Dry type with double elements and pre-cleaned, with dust indicator	



TRANSMISSION

Torque converter	3-elements, 1-stage, 2-phase	
Transmission	Full-automatic, planetary-shaft type	
Speed range	7 speeds forward and 1 reverse	
Lockup clutch	Wet, multiple-disc clutch	
Forward	Torque converter drive 1st and 2nd gear with direct drive lock-up in 1st through 7th	
Reverse	Torque converter drive	
Shift control	Electronic shift control with automatic clutch modulation in all gears	
Maximum travel speed	58 km/h	36 mph



AXLES

Rear axles	Full-floating	
Final drive type	Planetary gear	
Ratios:		
Differential	2.647	
Planetary	7.235	



SUSPENSION SYSTEM

Variable rate, hydropneumatic with integral rebound control.		
Maximum front stroke	375 mm	14.76"
Maximum rear stroke	106 mm	4.17"
Rear axle oscillation	+/- 9.2°	



STEERING SYSTEM

Type	Fully hydraulic power steering with two double-acting cylinders,	
Supplementary steering	Accumulator assist	
Minimum turning radius	12.2 m	40'
Steering angle (left or right)	41°	



CAB

Integral 4-post ROPS/FOPS Level 2 cab structure



MAIN FRAME

Type	Box-sectioned structure Integral front bumper	
------	--	--



BRAKES

Brakes meet ISO 3450 standard.		
Service brakes:		
Front	Fully hydraulic control, oil-cooled multiple-disc type	
Rear	Fully hydraulic control, oil-cooled multiple-disc type	
Parking brake	Spring applied, oil-released, 3 caliper dry disc mounted on input yoke to differential	
Retarder	Oil-cooled, multiple-disc front and rear brakes act as retarder.	
Secondary brake	Manual - push button operated. Automatically applied prior to hydraulic system pressure dropping below established level.	
Braking surface	159148 cm ²	24,668 in



BODY

Capacity:		
Struck	54 m ³	71 yd
Heaped (2:1, SAE)	78 m ³	102 yd
Nominal payload	144.1 metric tons	158.9 U.S. tons
Material	400 Brinell hardness high tensile strength steel (front, sides, and bottom)	
Structure	Flat floor configuration	
Material thickness:		
Bottom	19 mm	0.75"
Front	12 mm	0.47"
Sides	9 mm	0.35"
Target area (inside length x width) 7670 mm x 5705 mm 25'2" x 18'9"		
Dumping angle	45°	
Height at full dump	11440 mm	37'6"
Weight	19100 kg	42,108 lb



HYDRAULIC SYSTEM

Hoist cylinder	Two, 3-stage telescopic type	
Relief pressure	19.0 MPa	193.4 kg/cm ² 2,750 psi
Hoist time		
Raise	15 sec	
Lower	15 sec	



WEIGHT (APPROXIMATE)

Empty weight	105300 kg	232,144 lb
Nominal vehicle weight	249478 kg	550,000 lb
Weight distribution:		
Empty: Front axle	48.6%	
Rear axle	51.4%	
Loaded: Front axle	32.8%	
Rear axle	67.2%	



TIRES

Standard tire	33.00 R51
---------------	-----------



SERVICE REFILL CAPACITIES

Fuel tank	2120 L	560 U.S. Gal
Engine oil	193 L	51 U.S. Gal
Hydraulic system	900 L	238 U.S. Gal
Differential	297 L	78 U.S. Gal
Final drives (total)	240 L	63.5 U.S. Gal
Transmission	153 L	40.5 U.S. Gal
Cooling system	532 L	141 U.S. Gal



DIMENSIONS AND PERFORMANCE

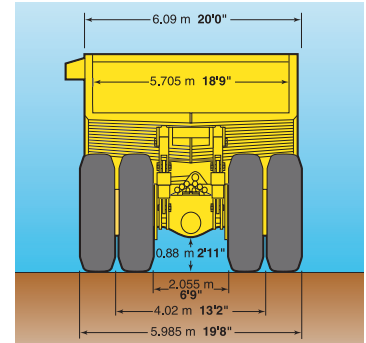
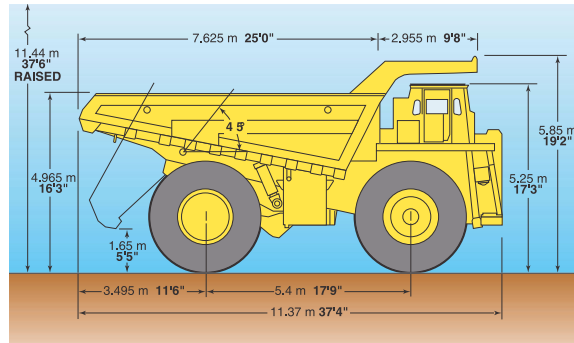
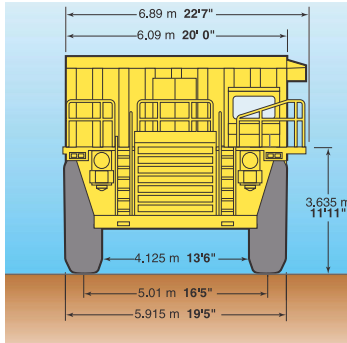

PROPULSION PERFORMANCE CHART

To determine travel speed during propulsion using this travel performance chart: Read from gross weight down to the percent of total resistance. From this weight-resistance point, read horizontally to the curve with the highest obtainable speed range, then down to maximum speed. Usable rimpull depends upon traction available and weight on drive wheels.

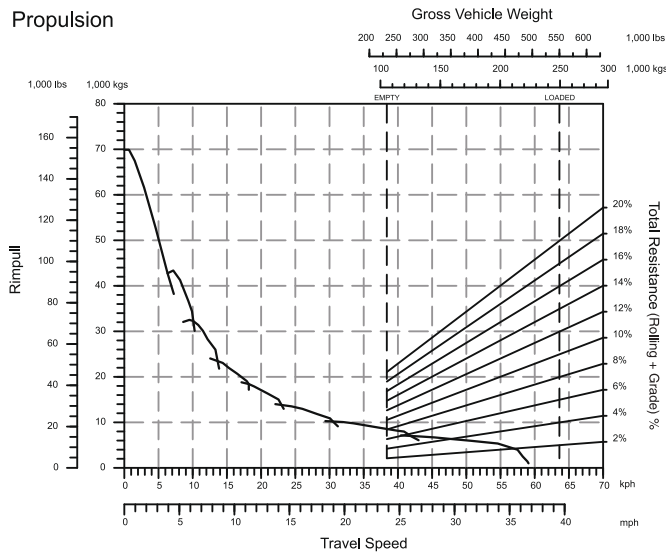

RETARDING PERFORMANCE CHART

To determine travel speed during retarding using this retarding performance chart: Read from gross weight down to the percent of total resistance. From this weight resistance point, read horizontally to the curve with the highest obtainable speed range, then down to maximum descent speed the brakes can safely handle without exceeding cooling capacity.

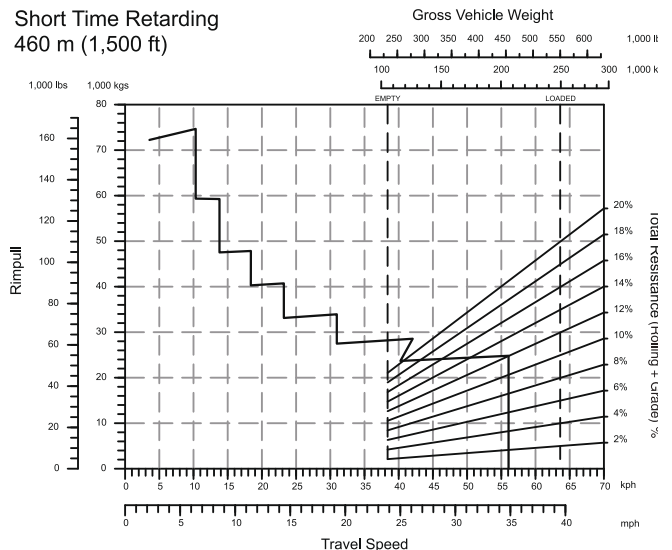
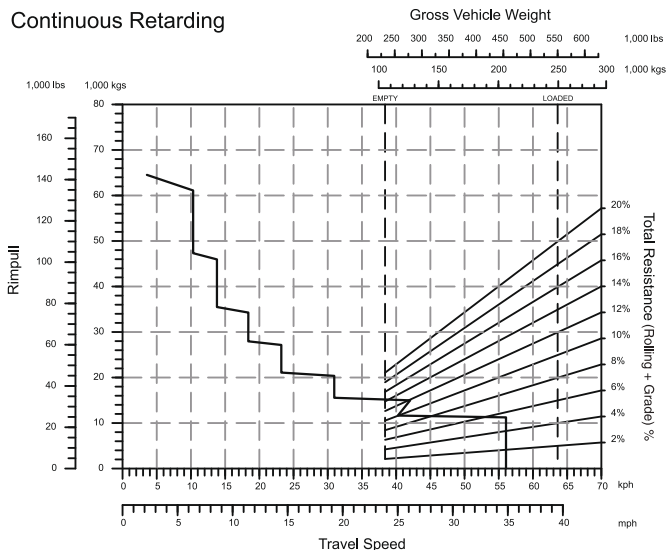



STANDARD EQUIPMENT

POWERTRAIN

- Air cleaner (2); battery disconnect; engine electronic control; engine electronic monitor; engine overspeed protection; engine pre-lube system; ground level shutdown; mufflers, deck mounted; variable speed engine fan (electronic-over-hydraulic)
- Powertrain Management (these items located in the cab):
 - transmission controller
 - retard controller
 - monitor display
 - data download port
- Seven-speed automatic transmission:
 - electronic control
 - body-up reverse interlock
 - body-up shift inhibitor
 - downshift/reverse shift inhibitor
 - neutral start switch
 - transmission belly guard
- Torque converter (electronic lockup control)

CAB

- Air conditioning (R134A)
- AM/FM/CD/USB/MP3
- Electric windows (both doors)
- Glass, tinted
- Heater/defroster
- Instrumentation (gauge and monitor):
 - speedometer
 - tachometer
 - engine coolant temperature
 - brake oil temperature

- fuel level
- shift indicator
- hourmeter
- odometer
- torque converter temperature
- warning lights
- Insulated and sound-suppressed
- Operator 3-point 51 mm 2" retractable seat belt
- Seat, air suspension (driver)
- Seat, passenger
- Side windows, tempered glass
- Steering wheel, tilt and telescopic
- Sun visor
- Windshield, laminated glass
- Windshield washer and wiper

LIGHTING

- Back-up light, rear (1)
- Back-up lights, deck-mounted (2)
- Clearance lights, front
- Engine service lights (2)
- Headlights, halogen (8)
- Hi-low beam selector
- Instrument panel lights
- Ladder lights, driver side
- Retarder lights (2)
- Stop and tail lights LED
- Turn signals LED

GENERAL

- Back-up warning alarm
- Body up cable
- Drive line protector (front and rear)
- Engine fan and pulley guards

- Exhaust pipe blanket
- Handrails
- Heat shield behind engine
- Horn (2)
- Ladder, deck-to-transmission
- Ladders, right and left (front)
- Mirrors, right and left
- Mud flaps
- Parking brake (3 caliper, spring-applied)
- Reverse hoist interlock
- Rock ejectors
- ROPS/FOPS Level 2 cab-integral 4-post
- Secondary brake system, automatic and manual
- Anti-slip walkway on deck
- Supplementary steering system, automatic

OTHER

- Auto-Retard Speed Control (ARSC)
- Automatic Spin Regulator (ASR)
- Automatic lubrication system
- Body mounting group
- Fast fill fuel system (Wiggins) right-hand side of the machine
- Integrated Komatsu Payload Meter
- KOMTRAX Plus
- Operation, parts, and maintenance manuals (1 set)
- Rims (6), 24 x 51 (for 33 x 51 and 33R51 tires)
- Tow hooks, front
- Tow pin, rear



OPTIONAL EQUIPMENT

(Optional equipment may change operating weight.)

- Body with cab and 236 mm **9.29"** spill guard
- Body sideboards 669 mm **26.34"**
- Disabled truck quick connects
- Ether start
- Fast fill fuel, Wiggins left-hand side
- Fire extinguisher
- Hub odometer, miles or kilometers
- Kim Hot Start
- Service center, Wiggins left-hand side
- Spare rim
- Suspension cylinder charging tool
- Tires, 33R51
- Tool kit

AESS727-03

©2013 Komatsu America Corp.

Printed in USA

AD04(500)CCi

04/13 (EV-2)

KOMATSU[®]