

KOMATSU®

730E

MAXIMUM GVW
324319 kg 715,000 lb
GROSS HORSEPOWER
1491 kW 2,000 HP

730E

ELECTRIC DRIVE TRUCK



Photo may include optional equipment.

730E ELECTRIC DRIVE TRUCK

SPECIFICATIONS



ENGINE

Make and model	Komatsu SSA16V159
Fuel	Diesel
Number of cylinders	16
Operating cycle	4 stroke
*Rated brake power	1491 kW 2,000 HP @ 1900 rpm
**Flywheel power	1388 kW 1,860 HP @ 1900 rpm
Weight (wet)	5294 kg 11,670 lb

NOTE: This engine includes the Engine Monitor System

*Rated brake power is the output of the engine as installed in this machine, at governed rpm and with engine manufacturer's approved fuel setting. Accessory losses included are water pump, fuel pump and oil pump.

**Flywheel power is the rated power at the engine flywheel minus the average accessory losses.

Accessories include fan and charging alternator. Rating(s) represent gross engine performance in accordance with SAE J1349 conditions.



ELECTRIC DRIVE

AC/DC CURRENT

Alternator	G.E. GTA-22
Control	Statex III Fuelsaver
*Motorized wheels	G.E. 788
**Ratio	26.825:1
Speed (maximum)	55.7 km/h 34.6 mph

*Wheel motor application depends upon gross vehicle weight, haul road grade, haul road length, rolling resistance and other parameters. Komatsu and G.E. must analyze each job condition to assure proper application.

**Optional ratios available.



TIRES AND RIMS

Rock service, tubeless, tires

*Standard tire	37.00 R57
Standard five (5) piece rim	686 mm x 1488 mm x 152 mm 27" x 57" x 6" patented Phase II New Generation rim assembly with patented 152 mm 6" double forged flanges. Not interchangeable with other manufacturers' rims due to improved design for greater load support and longer fatigue life.

*Tires should meet application requirements for tkph/tmph, tread, compound, inflation pressure, ply rating or equivalent, etc.



BODY

All-welded steel flat floor body with horizontal bolsters and full canopy. Eyebrow, rear wheel rock ejectors, body up cable and rubber mounts on frame are standard. Pivot exhaust heating optional.

Bottom plate	19 mm 0.75" 1379 mPa 200,000 psi tensile strength steel (two-piece)
Front sheet	12 mm 0.47" 1379 mPa 200,000 psi tensile strength steel
Side sheet	9 mm 0.35" 1379 mPa 200,000 psi tensile strength steel
Struck	77 m ³ 101 yd³
Standard SAE heaped 2:1	111 m ³ 145 yd³



CAB

Advanced Operator Environment with integral 4-post ROPS/FOPS structure (meets J1040 Apr88), adjustable air suspension seat with lumbar support and arm rests, passenger seat, maximum R-value insulation, tilt and telescoping steering wheel, electric windshield wipers with washer, tinted safety glass, power windows, Komatsu Payload Weighing System, 55,000 Btu/hr heater and defroster, 21,600 Btu/hr air conditioning (HFC - 134A refrigerant).



FRAME

Advanced technology, full butt-welded box-sectional ladder-type frame with integral ROPS supports, integral front bumper, rear tubular cross members, steel castings at all critical stress transition zones, rugged continuous horseshollar.

Plate material	482.6 mPa 70,000 psi tensile strength steel
Casting material	620.5 mPa 90,000 psi tensile strength steel
Rail width	279 mm 11"
Rail depth (minimum)	813 mm 32"
Top and bottom plate thickness	32 mm 1.25"
Side plate thickness	19 mm 0.75"
Drive axle mounting	High-mount ball and socket joint at front
Drive axle alignment	Swing link between frame and axle



BRAKING SYSTEM

Service brakes: all-hydraulic actuated

Front	Wheel speed disc. Three calipers on a 1168 mm 46.0" O.D. disc.
Rear	Dual disc armature speed. Two 635 mm 25" O.D. discs per side. One caliper per disc.
Emergency brakes	Automatically applied prior to hydraulic system pressure dropping below level required to meet secondary stopping requirements.
Wheel brake locks	Switch activated
Parking brakes	Spring-applied, hydraulically released, with speed application protection.
Electric dynamic retarder (max.)	2759 kW 3,700 hp
Continuously rated blown grids	Two-speed overspeed retarding.
Extended range retarding	Reverse retarding.



SUSPENSION

HYDRAIR® II

Variable rate hydro-pneumatic with integral rebound control.	
Maximum front stroke	335 mm 13.2"
Maximum rear stroke	279 mm 11.0"
Maximum rear axle oscillation	±9.75°



COOLING SYSTEM

L&M radiator assembly with sight gauge. Deaeration-type top tank. Dual pass cooling.

Radiator frontal area	4.33 m ² 46.6 ft²
-----------------------	--



SERVICE CAPACITIES

Cooling system	409 L .. 108 U.S. gal
*Crankcase	223 L .. 59 U.S. gal
Hydraulic system	731 L .. 193 U.S. gal
Motor gear box	.40 L .. 10.5 U.S. gal
Fuel	.3217 L .. 850 U.S. gal

*Includes lube oil filters



DIMENSIONS

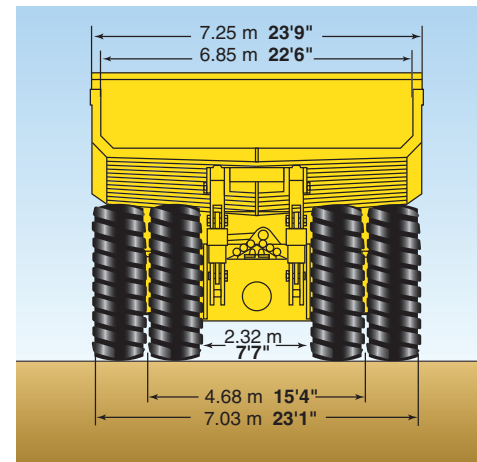
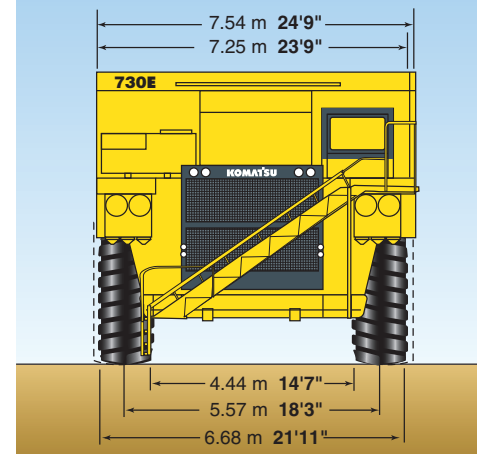
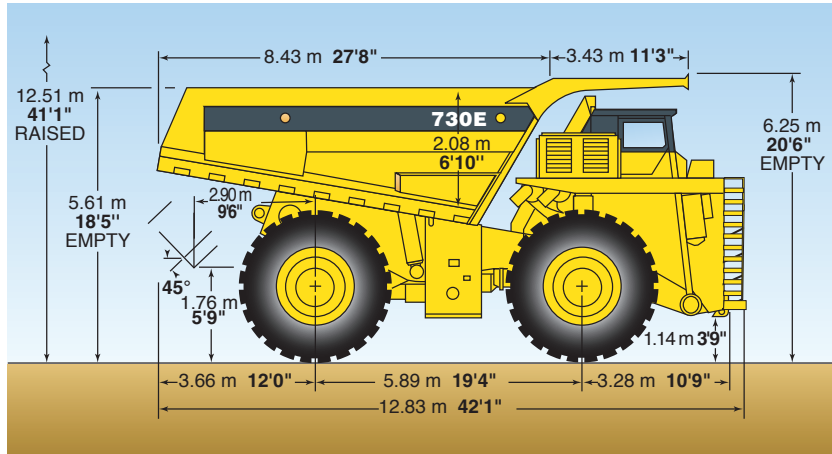

All dimensions are with 111 m³ 145 yd³ body.

Bodies	Struck	2:1 Heap	Loading Height*
Standard	77 m ³ 101 yd ³	111 m ³ 145 yd ³	5.61 m 18'5"

*Exact load height may vary due to tire make, type, and inflation pressure.



HYDRAULIC SYSTEM

- Steering Accumulator-assisted with twin cylinders provide constant rate steering. Emergency power steering automatically supplied by accumulator (meets SAEJ1511)
- Turning circle diameter (SAE) 28.0 m 92 ft
- Reservoir 731 L 193 U.S. gal
- Filtration In-line replaceable elements
- Suction Single, full-flow, 100 mesh
- Hoist and steering Dual, full-flow, in-line, high-pressure
- Brake component cabinet Above-deck, easily accessible with diagnostic test connector.
- Hoist Two 3-stage dual-acting outboard cylinders, internal cushion valve.
- Hoist times
 - Power-up loaded 21 sec
 - Power-down 15 sec
 - Float-down empty 22 sec
- Pumps
 - Hoist Gear-type pump with output of 513 lpm 135.6 gpm @1900 rpm and 17240 kPa 2500 psi
 - Steering and brake Vane-type pump with output of 235 lpm 62.0 gpm @1900 rpm and 18960 kPa 2,750 psi
- System relief pressures
 - Hoist 17240 kPa 2,500 psi
 - Steering and brake 27580 kPa 4,000 psi
- Quick disconnects standard for powering disabled truck and for system diagnostics.



ELECTRICAL SYSTEM

- 4 x 8D 1450 CCA, 12 volt batteries, in series/parallel, bumper-mounted with disconnect switch.
- Alternator 24-volt, 140 amp
- Lighting 24-volt
- Cranking motors two/24-volt



WEIGHT DISTRIBUTION

Empty vehicle weight (wet, 100% fuel, no options, std Komatsu body, std tires)			
Front axle	67484 kg		148,776 lb
Rear axle	73108 kg		161,174 lb
Total EVW	140592 kg		309,950 lb
Standard Komatsu body	25612 kg		56,464 lb
Standard tire weight	18371 kg		40,500 lb
Gross vehicle weight (Nominal)			
Front axle	98941 kg		218,129 lb
Rear axle	225377 kg		496,871 lb
Total	324319 kg		715,000 lb
Nominal payload*	183729 kg		405,050 lb
			203 U.S. ton

*Nominal payload is as defined within Komatsu America Corporation's payload policy documentation. Nominal payload must be adjusted should the weight of any customized body or tires fitted vary from that of the standard Komatsu body and tires as shown above. Nominal payload must also be adjusted to take into account the additional weight of any customized/optional extras fitted to the truck which are not stated within the Standard Features list of this specification sheet.



STANDARD EQUIPMENT

- Air cleaners, Donaldson SSG with dust evacuators
- Alternator (24 volt/140A)
- Auto lubrication system
- Batteries (4 x 8D, 1450 CCA 12 volt)
- Battery charging cable and socket
- Body left-side canopy protector
- Body over center device
- Brakes: Front wheel speed disc; rear - dual disc armature speed
- Diagonal Boarding ladder (RH to LH) with RH vertical ladder
- Electric start
- Fast-Fill Fuel System (in tank, right side)
- FLOC - fast lube oil change
- Filters, high pressure hydraulic
- Gate valves on hydraulic tank
- Komatsu control cabinet
- Komatsu Payload Weighing System—PLM III
- Mirrors, LH flat and RH rectangular convex
- Mud flaps
- Muffled exhaust, deck-mounted
- On board load box
- Power supply, 24 volt and 12 volt DC
- Quick disconnects (hoist, steering)
- Removable power module unit (radiator, engine, alternator, blower)
- Rock ejectors
- Radiator sight gauge
- Retard speed control
- Retard grids, continuous rated, 14 element
- Reverse retarding
- Thermostatic fan clutch
- Two-speed overspeed retarding
- Vari-volt alternator control

OPERATION ENVIRONMENT AND CONTROL:

- All hydraulic service brakes with emergency auto apply
- Battery disconnect switch
- Body up cable
- Brake lock and drive system interlock
- Circuit breakers, 24 volt

- Dynamic retarding with continuous rated grids
- Engine shutdown at ground level
- Exhaust blankets
- Hoist propulsion interlock
- Horns (back-up, front - electric)
- Integral roll-over protection (ROPS)
- Maintenance and power lockout
- Parking brakes with warning light and speed application protection
- Power steering w/auto emergency steering
- Protective deck handrails
- Pump driveline protector
- Radiator fan guard
- Skid-resistant coating on walkways

STANDARD HIGH VISIBILITY DELUXE CAB:

- Air cleaner vacuum gauges
- Air conditioner HFC 134A
- Alarm System warning lights (red)
 - Accumulator pre-charge
 - Coolant low level w/alarm
 - Coolant high temperature w/alarm
 - Electric drive system cooling blower w/alarm
 - Electric system fault w/alarm
 - Hydraulic oil level w/alarm
 - Hydraulic oil temperature w/alarm
 - Low engine oil pressure w/alarm
 - Low brake pressure w/alarm
 - Motorized wheel temperature stop engine w/alarm
 - Steering pressure w/alarm
- AM/FM, CD with Weather Band, Aux and IPOD Inputs
- Engine monitoring system
- Digital tachometer and speedometer
- Dome light
- Double door seals
- Engine hourmeter, oil pressure gauge, water temperature gauge
- Engine shutdown w/5 minute delay timer
- Floor mat
- Fuel gauge in cab and on tank
- Gauges (w/back light)
- Headlight switch
- Heater and defroster (heavy-duty)
- Heater switch

- High beam selector and indicator
- Indicator lights (amber):
 - 5-minute idler timer
 - Auto lube alarm
 - Check engine w/alarm
 - Circuit breaker tripped
 - Dynamic retarding
 - Dump body up
 - Hydraulic oil filter
 - Low fuel level
 - Manual back-up lights
 - Park brakes applied
 - Retard speed control
 - Service brakes
 - Starter circuit
- Horn (center of steering wheel)
- Independent brake/retarder pedals
- RS232 port - Statex III-PLM III
- Insulation (Max R-Valve)
- Oil pressure gauge
- Operator seat, adjustable w/air suspension and 3 point seat belt
- Panel lighting (adjustable)
- Passenger seat
- Power windows
- Pressurized cab air system
- Starter key switch
- Sunvisor (adjustable)
- Tilt and telescoping steering wheel
- KOMTRAX Plus
- Voltmeter (battery output)
- Wheel brake lock w/drive system interlock
- Windshield wipers, dual, washer (electric)
- Windshield (tinted)

LIGHTING:

- Back-up lights-rear mount (2)
- Brake and retard lights on top of cab
- Control cabinet service light
- Headlights - (4) halogen
- Ladder lights
- LED Clearance lights- Amber front, red rear
- LED Dynamic retarding lights, rear
- LED Stop and tail lights
- Manual back-up light, switch and indicator
- Service light in rear axle
- Turn signals
- Under-hood service lights



OPTIONAL EQUIPMENT

(Optional equipment may change operating weight).

- 7-step Extended Range Retarding (ERR)
- Additional high-mounted headlights
- Arctic protection package (suspensions, antifreeze/lube below -40° C)
- Back-up lights, deck mounted
- Body liners*
- Exhaust-heated body
- Filtered air inlet system
- Fire extinguisher 9 kg **20 lb**
- Fog lights—Halogen (2) lower grille
- Hot start (engine oil, coolant, hydraulic tank)
- Hubometer (miles or kilometers)
- Modular Mining System (MMS) ready
- Motorized wheel ratio's (higher/lower)
- Mufflers between frame rails
- Payload Scoreboard Displays (RH and LH)
- Pressure fueling, LH remote*
- Radiator shutters
- Trolley assist package
- Service Center—RH
- Special language decals

*Available factory-installed or non-installed. All other options and accessories listed are available factory installed only.

AE5564-07

©2012 Komatsu

Printed in USA

K01(500) C

01/12 (EV-1)

KOMATSU®