

KOMATSU®

960E-2

GROSS HORSEPOWER

2610 kW **3,500 HP**

NOMINAL GVW

576072 kg **1,270,000 lb**

960E

ELECTRIC DRIVE TRUCK



Photos may include optional equipment

WALK-AROUND

Productivity Features

- High performance Komatsu SSDA18V170 engine
Gross horsepower 2610 kW **3,500 HP**
- GE dual IGBT AC electric drive system
- 4476 kW **6,000 HP** continuous retarding capability
- Automatic retard speed control
- Traction (spin-slide) control
- Customer specific body
- Tight turning radius 16 m **52' 6"**
- Payload Meter III®

Environmentally Friendly

- Optional Tier 4 compliant Komatsu SSDA18V170 engine
- Fuel efficient engine

Reliability Features

- Frame structurally enhanced for 327 tonne **360 short ton** payload
- Proven wheelmotor design
- Simple and reliable hydraulic system
- Steering and brake accumulators
- Hydraulically actuated multiple-disc wet brakes



GROSS HORSEPOWER
2610 kW 3,500 HP @ 1900 rpm

NOMINAL GVW
576072 kg 1,270,000 lb

Operator Environment

- Ergonomically designed spacious cab with improved visibility
- Fully adjustable driving position settings
- Four post ROPS/FOPS Level 2 Cab
- Advanced dash panel with payload display
- AM/FM/CD/MP3/USB radio



Easy Maintenance

- KOMTRAX Plus allows immediate diagnostics of key engine, chassis, and drive system components
- Oil-cooled wet disc braking system reduces wear and extends component replacement intervals
- Extended oil change intervals based on the Centinel® and Reserve systems
- Automatic lubrication system
- Eliminator® oil filtration system
- In-tank fast fuel fill system

PRODUCTIVITY FEATURES

Komatsu SSDA18V170 High Horsepower Engine

Komatsu's SSDA18V170 engine was designed and developed by Industrial Power Alliance (IPA) technical joint venture between Komatsu and Cummins®. This 2610 kW **3,500 HP** engine will operate in most of today's mining applications without experiencing power derate. Fuel efficiency is maximized due to optimized air handling with two-stage turbocharging. A standard pre-lube system is designed to eliminate start-up wear and increase overhaul life. Standard features include:

- CENSE® on board monitoring of engine performance for each cylinder
- CENTINEL® Advanced Engine Oil Management System with Reserve oil
- ELIMINATOR® filtration system reduces oil and filter changes by one-third



Electric Dynamic Retarder

The 4476 kW **6,000 HP** retarding system provides state of the art braking capacity for navigating today's mining applications which contain steep continuous descents and sharp switchbacks.

Continuous retarding capacity enhances the productivity of the vehicle operator, while eliminating the need for excessive mechanical braking effort.



GE Dual IGBT AC Electric Drive System

Invertex® AC control system offers independent control of the rear wheelmotors, which in turn provides outstanding traction-ability during wet and slippery conditions, thus improving tire wear and operator confidence.

The air cooled Insulated Gate Bipolar Transistor (IGBT) inverter system technology provides the highest available reliability. The IGBT inverter is more compact and much simpler than the design of its predecessor, the Gate Turn Off (GTO) inverter, which improves serviceability and routine maintenance.



Traction (Spin-Slide) Control

During slippery events caused by inclement weather conditions and/or application severity, the 960E wheel Spin-Slide prevention technology will detect and correct any wheel spin control events. Spin-Slide Control operates automatically and independently of the service brakes. During propulsion, "wheel slip control" reduces non-productive wheel spin in low traction conditions. During retarding, "wheel slide control" prevents wheel lockup and subsequent sliding.

Automatic Retard Speed Control

While in continuous descent, the operator has the capability to select a comfortable downhill travel speed. Automatic Retard Speed Control simultaneously manages the speed of each wheel independently to allow for any immediate adjustments needed during slippery underfoot conditions.

Customer Specific Body

For all trucks, Komatsu goes through the Body Worksheet (BW) process to ensure that each body is designed to meet the requirements for each specific application while carrying its rated payload. Komatsu works with each customer to understand all of the material properties at a mine site and to identify the appropriate liner package.

Komatsu offers a standard all-welded steel, flat floor body with a full canopy and horizontal bolsters. This body includes a driver side eyebrow, body up sling, and rubber mounts on the frame.

- Standard Body Struck Capacity: 149 m³ **195 yd³**
- Standard Body SAE Heaped 2:1: 214 m³ **280 yd³**
- Standard Komatsu Body Weight: 40823 kg **90,000 lbs**



Tight Turning Radius

By using double acting hydraulic steering cylinders with a six-point articulation linkage, the 960E-2 power steering system provides steering control with minimal operator effort. The turning radius of the 960E-2 is 16 m 52' 6", which provides excellent maneuverability for tight loading and dumping conditions. The steering accumulators comply with ISO-5010 standards.

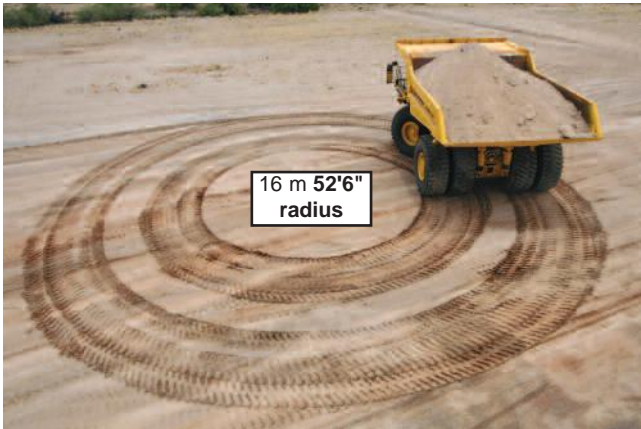
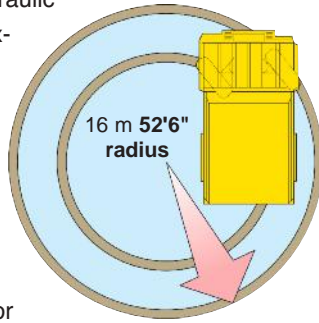

Payload Meter III® (PLM III)

PLM III is an electronic system that monitors and records payload information for Komatsu's off-highway mining trucks. The accurate and reliable payload measurement system is designed to help optimize payload, maximize productivity and reduce the life cycle cost of the machine. PLM III tracks and records the following key production parameters:

- Payload
- Empty Carry-Back
- Operator Identification
- Haul Cycle, Loading, Dumping Time and Date
- Distance Traveled (Loaded and Empty)
- Cycle Time Information
- Maximum Speeds (Loaded and Empty)
- TMPH Estimate for Front and Rear Tires
- Average Speed (Loaded and Empty)

Example of Payload Summary

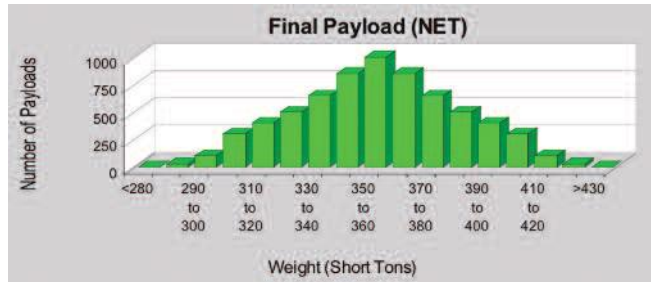

Hydropneumatic Suspension

Hydrair II® is a suspension system that utilizes four nitrogen-over-oil cylinders. This suspension system is designed to maximize machine productivity by providing the operator with a smooth and comfortable ride. By absorbing shocks to the chassis during operation, Hydrair II® contributes to the durability of the machine's frame and components.

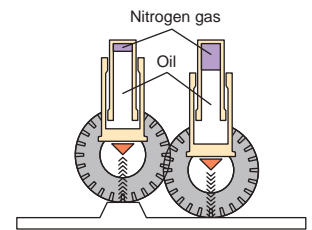

OPERATOR ENVIRONMENT

Ergonomically Designed Cab

The Komatsu 960E-2 cab design provides a comfortable and productive environment to meet today's mining demands. The cab includes tinted windows, heating and air conditioning, acoustical insulation, double sealed doors, and provides filtered and pressurized air.

Operator Seat

Komatsu recognizes that operator comfort is a key to productivity in today's mining environment. The five-way adjustable operator seat and the tilt-telescopic steering column provide an optimum driving posture for increased operator comfort and control over the machine. The air suspension seat absorbs vibrations transmitted from the machine, reducing operator fatigue. A 51 mm 2" wide three-point seat belt is provided as standard equipment.

Built-in ROPS and FOPS Structure

Integral ROPS/FOPS Level 2 cab. These structures conform to ISO standards 3471 and 3449.

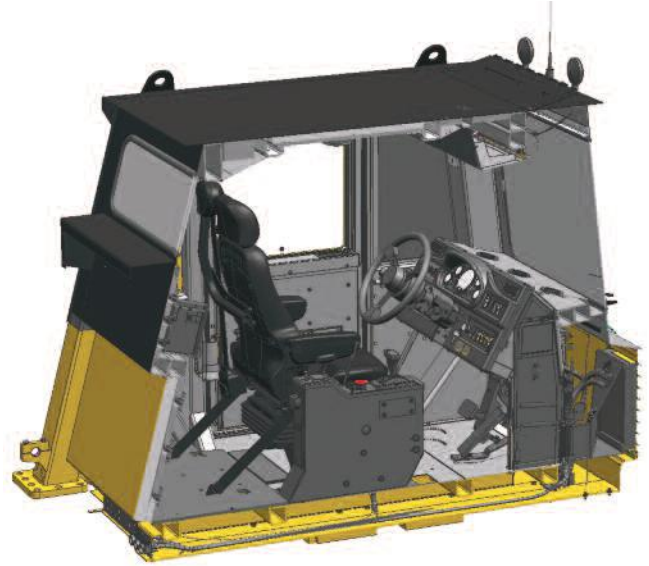
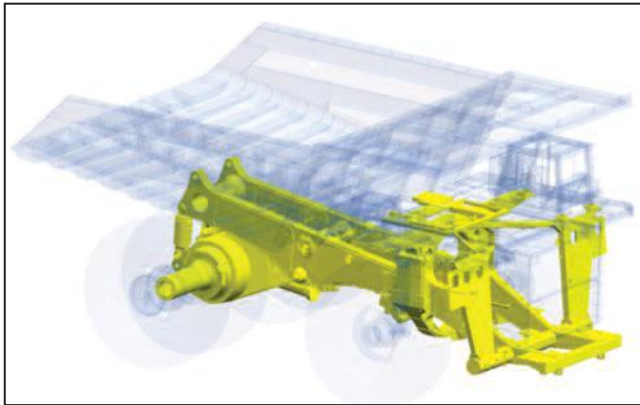

Photo may include optional equipment

RELIABILITY FEATURES

Structurally Enhanced Frame Design

By using advanced computer-aided design, finite element analysis, and full-scale dynamic and static testing, the frame design has been structurally enhanced to carry 327 tonne **360 short tons** and provides the highest reliability in the industry.



Simple and Reliable Hydraulic System

The hydraulic system is a proven and reliable design with fewer parts than other OEMs. The system utilizes a common tank, and therefore, common fluid for steering, braking, and hoisting. In-line, replaceable filtration elements provide additional hydraulic system protection from contamination.

To keep downtime to a minimum, Komatsu developed a sub-frame pump module that can be removed and replaced as a single unit. This reduces change-out time and allows easy access to the hydraulic pump module.



Castings Used in High Stress Areas

To increase frame reliability, steel castings have been incorporated at key frame pivot points and key load bearing critical portions of the frame. This includes the rear body pivot and horsecollar sections.

Steering and Brake Accumulators

In the event that the hydraulic pressure in the steering or braking system drops below an acceptable minimum, nitrogen-charged accumulators will automatically apply the brakes so that the truck may be stopped. There are separate accumulators for the braking and steering systems.



Proven Wheelmotor Design

The GDY108 has a redundant brake and transmission fluid sealing arrangement for better reliability and an improved oil drain system for easier maintenance.

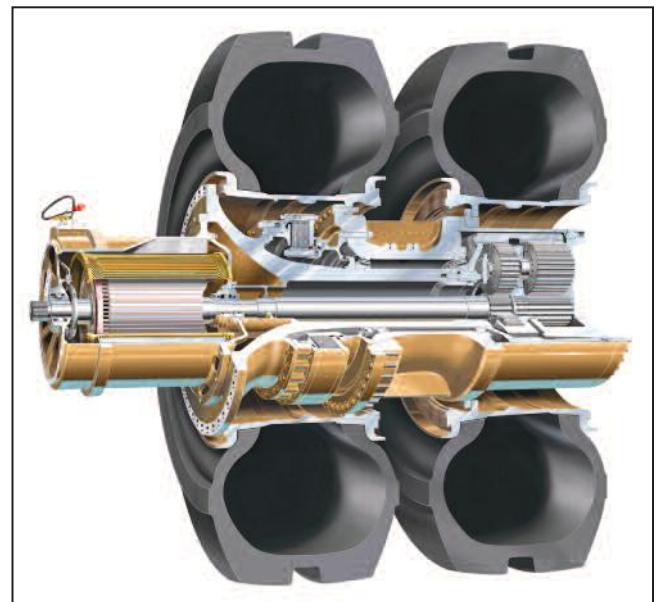

Fully Hydraulic Controlled Multiple-Disc Wet Brakes

Although the dynamic retarding system is the primary braking force, the 960E-2 comes standard with four-wheel, hydraulically actuated, oil cooled service brakes. In the event that the truck's hydraulic system pressure drops below an acceptable level, accumulator tanks will automatically apply all wheel brakes to bring the truck to a complete stop.

- Max. service apply pressure: 18960 kPa **2,750 psi**
- Total friction area per brake: 103729 cm² **16,078 in²**

The oil cooled brake system provides lower maintenance costs and higher reliability versus dry disc brakes. This system is fully sealed to help keep contaminants out and reduce brake wear and maintenance. The brakes are hydraulically actuated, removing all air from the design. By eliminating an air system, air bleeding is not required and water condensation that can lead to contamination, freezing, and corrosion is no longer present. There are three independent hydraulic circuits that provide hydraulic back-up.



EASY MAINTENANCE

Advanced Monitoring System – On-board Diagnostics

The Komatsu advanced monitoring system identifies maintenance items to the operator, reduces diagnostic times, indicates oil and filter replacement hours, and displays fault codes. This monitoring system is designed to maximize machine availability.

Automatic Lubrication System

The automatic lubrication system is designed to reduce downtime for lubrication by having a centralized location that automatically distributes grease to all lubrication points.



Flange Type Tire Rims

The flange type rims allow quicker removal and installation of the tires which minimizes the overall impact on downtime.



KOMTRAX Plus

As part of a complete service and support program, Komatsu equips every mining and quarry sized machine with KOMTRAX Plus. By using a satellite-based communication system, KOMTRAX Plus offers a new vision of monitoring your valuable assets by providing insight to critical operating metrics and information that can be used to increase availability, lower owning and operating costs and maximize fuel efficiency.

The KOMTRAX Plus information available on MyKomatsu.com allows service personnel and asset owners to review cautions, operational data, fuel consumption, payloads and key component measurements provided in forms of trends. With KOMTRAX Plus, knowledge becomes the power to fuel your productivity.



Extended Oil Change System

Cummins CENTINEL® oil management system and ELIMINATOR® filtration system reduce oil and filter changes by one-third. Oil drain is extended to 4,000 hours, and there are no spin-on oil filters. Centrifuge paper is replaced every 1,500 hours.



ADDITIONAL FEATURES

Environmentally Friendly

Komatsu SSDA18V170 Engine

Optional Tier 4 compliant Komatsu SSDA18V170 engine.

Less Fluids Than Mechanical Drives

Komatsu electric drive trucks contain 57% less fluid compared to similar class mechanical drive trucks, creating a lower environmental impact and makes fluid replacement simpler, quicker and more economical.

Selectable Stairway Direction



Komatsu's 960E-2 offers stairway access with entry from either the right or left side of the truck depending on the customer's preference.

Payload Policy

10-10-20 Load Policy Criteria

Recognizing that variation occurs naturally in material density, fill factors, and loading equipment, Komatsu America Corp. deems it necessary to establish a consistent payload policy. This payload policy is intended to identify the guidelines and limitations for the loading of Komatsu mining trucks, and is valid for approved applications and haul profiles only.

- 1) The average monthly payload must not exceed the rated payload of the truck
- 2) 90% of all loads must be below 110% of the rated payload of the truck
- 3) 10% of all loads may be between 110% and 120% of the rated payload of the truck
- 4) No single payload may exceed 120% of the rated payload of the truck

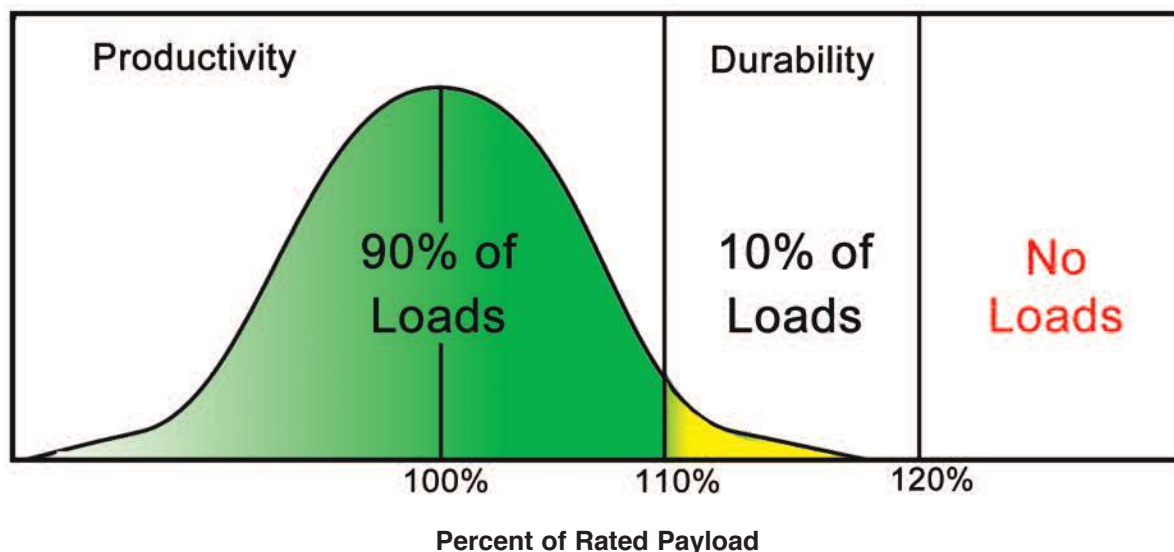

SPECIFICATIONS



ENGINE

Make and model*	Komatsu SSDA18V170
Fuel	Diesel
Number of cylinders	18
Operating cycle	4 cycle
Gross horsepower**	2610 kW 3,500 HP @ 1900 rpm
Net flywheel power***	2495 kW 3,346 HP @ 1900 rpm
Weight (wet)	11750 kg 25,897 lb
(dry)	11250 kg 24,795 lb

* Optional Tier 4 emission compliant engine for North American market. Non-emissionized engine for markets outside of North America.
 ** Gross horsepower is the output of the engine as installed in this machine, at governed rpm and with engine manufacturer's approved fuel setting. Accessory losses included are water pump, fuel pump and oil pump.
 *** Net flywheel power is the rated power at the engine flywheel minus the average accessory losses. Accessories include fan and charging alternator. Rating(s) represent net engine performance in accordance with SAE J1349 conditions.



ELECTRIC DRIVE

AC/DC CURRENT

Alternator	GTA-39
Dual impeller in-line blower	340.m ³ /min 12,000 cfm
Control	AC Torque Control System
Motorized wheels*	GDY108 Induction Traction Motors
Ratio	32.62:1
Speed (maximum)	64.5 km/h 40 mph

* Wheel motor application depends upon gross vehicle weight, haul road grade, haul road length, rolling resistance and other parameters. Komatsu and G.E. must analyze each job condition to assure proper application.



TIRES AND RIMS

Rock service, tubeless, radial tires	
Standard tire*	.56/80 R63
Flange mount rim	
1041 mm x 1600 mm x 140 mm	41" x 63" x 5.5" rim assembly.
Rims rated at 758 kPa	110 psi cold inflation pressure.
Typical tire weight	29553 kg 65,154 lb

* Tires should meet application requirements for tkph/tmph, tread, compound, inflation pressure, ply rating or equivalent, etc.



BODY

All-welded steel flat floor body with horizontal bolsters and full canopy. Eyebrow, rear wheel rock ejectors, body up sling and rubber mounts on frame are standard. Pivot exhaust heating optional.

Floor sheet	16 mm 0.63" Outer 19 mm 0.75" Center 1379 MPa 200,000 psi tensile strength steel
Front sheet	10 mm 0.39" Outer 12 mm 0.47" Center 1379 MPa 200,000 psi tensile strength steel
Side sheet	10 mm 0.39" 1379 MPa 200,000 psi tensile strength steel
Canopy sheet	6 mm 0.24" 690 MPa 100,000 psi tensile strength steel
Capacity struck	149 m ³ 195 yd³
SAE heaped 2:1	214 m ³ 280 yd³
Standard Komatsu body weight	40823 kg 90,000 lb



CAB

Advanced Operator Environment with integral 4-post ROPS/FOPS Level 2 cab, adjustable air suspension seat w/lumbar support and arm rests, full-size passenger seat, maximum R-value insulation, tilt and telescoping steering wheel, electric windshield wipers w/washer, tinted safety glass, power windows, Komatsu Payload Weighing System, 61,000 Btu/hr heater and defroster, 19,900 Btu/hr air conditioning (HFC - 134A refrigerant).



FRAME

Advanced technology, full butt-welded box sectional ladder-type frame with integral ROPS supports, integral front bumper, rear tubular cross members, steel castings at all critical stress transition zones, rugged continuous horsecollar.	
Plate material	482.6.MPa 70,000 psi tensile strength steel
Casting material	.620.5 MPa 90,000 psi tensile strength steel
Rail width	305 mm 12"
Rail depth (minimum)	864 mm 34"
Top and bottom plate thickness	45 mm 1.77"
Side plate thickness	.25 mm 0.98" Rear 32 mm 1.26" Front
Drive axle mounting	Pin and spherical bushing
Drive axle alignment	Swing link between frame and axle



BRAKING SYSTEM

Service brakes: oil-cooled, hydraulic-actuated, multiple disc brakes at each wheel. Traction system wheel spin-slide control.	
Max. service apply pressure	.18960.kPa 2750 psi
Total friction area per brake	.103729 cm ² 16,078 in²
Secondary brakes	Automatically applied prior to hydraulic system pressure dropping below level required to meet secondary stopping requirements.
Wheel brake locks	Switch activated
Parking brakes	Multiple disc, spring-applied, hydraulically-released, dry brakes on inboard end of each wheel rotor shaft. Rated to hold on ±15% grade at maximum gross vehicle weight.
Electric dynamic retarder	Continuous 4476 kW 6000 hp
Continuously rated high-density blown grids w/retard capacity at low speeds and retard in reverse propulsion.	



SUSPENSION

Variable rate hydro-pneumatic with integral rebound control	
Max. front stroke	328 mm 12.92"
Max. rear stroke	239 mm 9.40"
Max. rear axle oscillation	±6.5°



COOLING SYSTEM

L&M radiator assembly, split-flow, with deaerator-type top tank.	
Radiator frontal area	.7.02.m ² 75.5 ft²



SERVICE CAPACITIES

Cooling System	.7.19 L. 190 U.S. gal
Crankcase*	341 L. 90 U.S. gal
Hydraulic system	.1325.L. 350 U.S. gal
Motor gear box (each)	.95.L. 25 U.S. gal
Fuel	5300.L 1400 U.S. gal

* Includes lube oil filters



DIMENSIONS

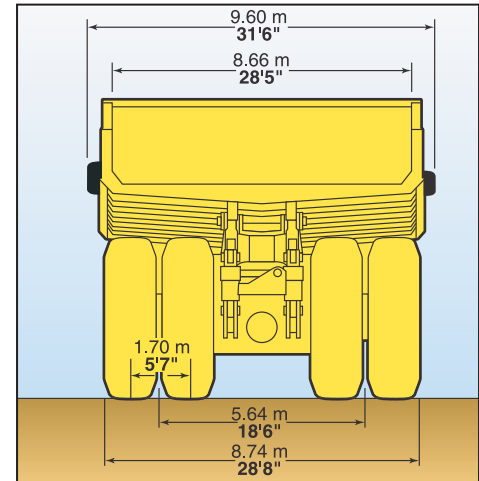
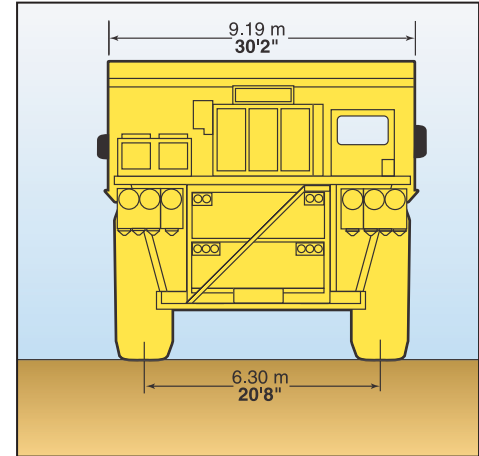
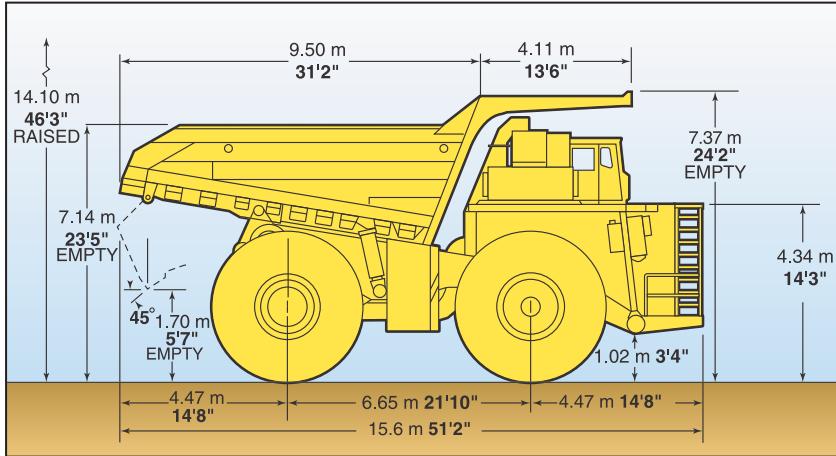

All dimensions are with standard body.

Body	Capacity		Loading Height*
	Struck	2:1 Heap	
Standard	149 m ³ 195 yd ³	214 m ³ 280 yd ³	7.14 m 23'5"

*Exact load height may vary due to tire make, type, and inflation pressure.



HYDRAULIC SYSTEM

- Steering . . . Accumulator assisted with twin double acting cylinders provide constant rate steering. Secondary steering automatically supplied by accumulator.
- Turning circle diameter (SAE)32 m **105'**
- Reservoir 947 L. **250 U.S. gal**
- Filtration In-line replaceable elements
- Suction Single, full flow, 100 mesh
- Hoist and steering Dual, in-line, high pressure
- Brake component cabinet Above deck, easily accessible with diagnostic test connections
- Hoist Two 3-stage dual-acting outboard cylinders, internal cushion valve, over-center dampening
- Hoist times
 - Power-up loaded 24 sec.
 - Power-down 14 sec.
 - Float-down empty 24 sec.
- Pumps Two pumps, single package, end of alternator
- Hoist and brake cooling Tandem gear pump with output of 931 lpm **246 gpm** at 1900 rpm and 18960 kPa **2,750 psi**
- Steering and brake Pressure-compensating piston pump with output of 246 lpm **65 gpm** at 1900 rpm and 20685 kPa **3,000 psi**
- System relief pressures
 - Hoist and brake cooling 17237 kPa **2,500 psi**
 - Steering and brake 20685 kPa **3,000 psi**
- Quick disconnects standard for powering disabled truck and for systems diagnostics.



ELECTRICAL SYSTEM

- 4 x 8D 1450 CCA, 12 volt, in series/parallel, 220-ampere-hour batteries, bumper-mounted with disconnect switch.
- Alternator 24 volt, 250 amp
- Lighting 24 volt
- Cranking motors Two/24 volt

960E-2 ELECTRIC DRIVE TRUCK

PERFORMANCE CHART

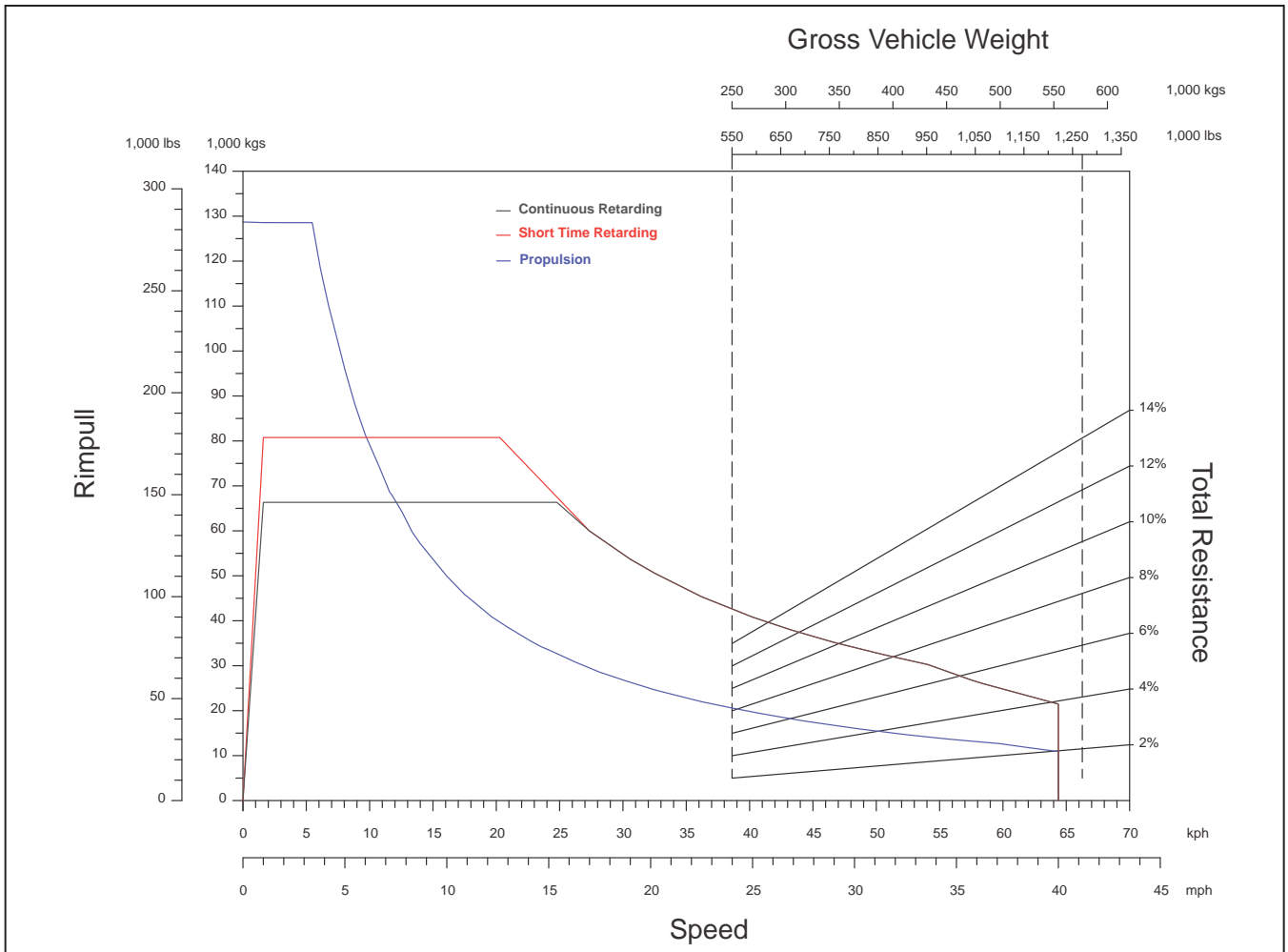

Short Time Retarding - While thermal conditions permit, short time retarding performance will be utilized.

KOMATSU PRODUCT LINE LOADER/TRUCK MATCHING

Typical Number of Passes to Load

		Komatsu Trucks							
		HD785 100 ton	HD1500 159 ton	730E 203 ton	830E-AC 244 ton	860E-1K 280 ton	930E-4 320 ton	930E-4SE 320 ton	960E 360 ton
KOMATSU EXCAVATORS	PC2000 15.7 yd ³	4	7						
	PC3000 19.5 yd ³	4	6	7					
	PC4000 29 yd ³	3	4	5	6	6			
	PC5500 37 yd ³		3	4	5	5	6	6	7
	PC8000 55 yd ³				3	3	4	4	5

Nominal truck payload rating (short tons)
Bucket ratings are based on 1780 kg/lcm **3,000 lbs/lcy** material density.

Empty Vehicle Weight

Front Axle Distribution	123490 kg	272,250 lbs	49.5%
Rear Axle Distribution	125985 kg	277,750 lbs	50.5%
Total EVW	249475 kg	550,000 lbs	

Gross Vehicle Weight

Front Axle Distribution	190104 kg	419,100 lbs	33.0%
Rear Axle Distribution	385968 kg	850,900 lbs	67.0%
Nominal GVW	576072 kg	1,270,000 lbs	

Payload

Nominal Payload	326585 kg	720,000 lbs	
	327 metric tons	360 short tons	

Nominal payload is defined by Komatsu America Corp's payload policy documentation. In general, the nominal payload must be adjusted for the specific vehicle configuration and site application. The figures above are provided for basic product description purposes. Please contact your Komatsu distributor for specific application requirements.





STANDARD EQUIPMENT

- Air cleaners, Donaldson® w/evacuators
- Alternator (24 volt/250A)
- Auto lubrication system w/ground level fill & level indicator
- Back up alarm
- Batteries—4 x 8D (1450 CCA's)
- Battery charging cable and socket
- Body over center device
- Body impact plate
- Brakes: oil-cooled, multiple disc front & rear
- Deck guard rails
- Electric start
- Eliminator®, Centinel®, Cense®
- Fast-fill fuel system (in tank and left side remote)
- Filters, high pressure hydraulic
- Fuel tank sight gauge (3)
- Ground level radiator fill
- L&M Radiator
- Mud flaps
- Muffled exhaust—deck-mounted
- Power supply, 24 volt and 12 volt DC
- Quick disconnects (hoist and diagnostics)
- Radiator sight gauge
- Removable power module unit (radiator, engine, alternator, blower)
- Retard speed control
- Reverse retarding
- Service center—LH
- Thermostatic fan clutch

OPERATOR ENVIRONMENT & CONTROL

- All hydraulic service brakes w/auto apply
- Battery disconnect switch
- Body up sling
- Brake lock and drive system interlock
- Circuit breakers, 24 volt
- Dedicated auxiliary circuits in operator cab (ladder lights, 2-way radios, fire suppression power)
- Diagonal ladder tread cap plates
- Dynamic retarding with continuous rated element grids
- Engine access guard rail
- Engine shutdown at ground level
- Hoist propulsion interlock
- Horns (electric—front and back-up)

- Hydraulic tank ladder
- Integral ROPS/FOPS Level 2 cab
- Maintenance and power lockout
- Parking brakes with warning light & speed application protection
- Power steering w/auto secondary steering
- Protective deck handrails
- Pre-shift brake test
- Pump driveline protector
- Radiator fan guard
- RH & LH multi-cambered convex mirrors
- Seat belts
 - Operator 3-point 51 mm 2" retractable
 - Passenger lap 51 mm 2" retractable
- Slip-resistant / dimpled surface on walkways
- Stairway-selectable direction (L to R)

STANDARD HIGH VISIBILITY DELUXE CAB

- AC drive interface display
- Actia Dash & Status Panel
 - Body up
 - Parking brake
 - Propulsion system not ready
 - No DC link voltage
 - High engine oil temp
 - No propel
 - Service brake applied
 - Wheel brake lock applied
 - Maintenance monitor
- Air cleaner vacuum gauges
- Air conditioner HFC-134A
- AM/FM radio with CD, USB & MP3
- Column-mounted retarder control
- Digital tachometer and speedometer
- Dome light
- Engine hourmeter, oil pressure gauge, coolant temperature gauge, hydraulic oil temperature gauge
- Engine shutdown w/ "Smart Timer" delay
- Floor mat (double barrier)
- Fuel gauge in cab
- Fuel low level light and buzzer
- Gauges (w/backlight)
- Headlight switch
- Heater and defroster (heavy-duty)
- Heater switch

- High beam selector and indicator
- Horn (center of steering wheel)
- Indicator lights (blue)
 - Engine service
 - KOMTRAX Plus snapshot (IM)
- Insulation (Max R-Value)
- Komatsu Payload Meter III®
- KOMTRAX Plus with ORBCOMM
- Operator seat, adjustable w/air suspension, lumbar support and arm rests
- Panel lighting (adjustable)
- Passenger seat, mechanical suspension
- Power windows
- Pressurized cab air system w/fan on
- Single brake/retarder pedal
- Starter key switch
- Sunvisor (adjustable)
- Tilt & telescoping steering column
- Voltmeter (battery output)
- Windshield (tinted safety plate)
- Windshield wiper (dual) and washer (electric)

LIGHTING

- Back-up lights—rear mount (2) halogen
- Back-up lights—R and L - deck mount (2) halogen
- Brake and retard lights on top of cab
- Clearance lights (LED)
- Control cabinet service light (LED)
- Dynamic retarding, rear (2) (LED)
- Engine compartment service lights
- Fog lights (2) halogen
- Halogen headlights- all high & low beam positions (10)
- HID-style backup/ berm light
- Manual back-up light, switch and indicator
- Payload lights R and L (LED)
- Platform lights R, L and Center
- Recessed corner marker/ signal lighting (LED)
- Stairway lights
- Stop & tail lights (2) (LED)
- Turn signals (LED)
- Under-hood service lights
- Work/ deck lights on control cabinet



OPTIONAL EQUIPMENT

Note: Optional equipment may change operating weight.

- Accumulators (cold weather)
- Antifreeze (-40°C)
- Body Liners*
- Bumper mounted headlights
- Engine access platform
- Extended canopy
- Eyebrow
- Fire extinguisher 9 kg 20 lb
- Heated body
- HID headlights
- Hot start engine coolant (220V 2-2500W)
- Hot start engine oil (220V 2-500W)
- Hot start hydraulic oil
- Hydraulic folding access ladder
- ISRI 3 point seat
- Mudflaps on hydraulic tank & fuel tank
- Mudflaps on hydraulic tank & fuel tank without ladder on hydraulic tank
- Reversed access ladder (R to L)
- Scoreboard PLM III Display
- Service center—RH
- Shutters (radiator)
- Special language decals
- Suspensions, cold weather
- Wiggins Quick Fluid Fill & Engine Oil Evacuation System

*Available factory installed or non-installed. All other options and accessories listed are available factory installed only.

AESS832-00

©2011 Komatsu America Corp.

Printed in USA

AD10(1.5M)OSP

10/11 (EV-1)

KOMATSU®

www.KomatsuAmerica.com

Eliminator®, Centinel®, Cense®
trademarks of Cummins Inc., U.S.A.

Komatsu America Corp. is an authorized licensee of Komatsu Ltd.
Materials and specifications are subject to change without notice
KOMATSU is a registered trademark of Komatsu Ltd., Japan
KOMTRAX Plus is a trademark of Komatsu America Corp.